

series 40

Minitransporter



Ed. 0

UK USER'S MANUAL AND MAINTENANCE



This manual should always be readily available so that the machine operator may consult it immediately, and it must be saved for the entire duration of the machine's life.

© 2006 – The entire or partial reproduction and/or divulging of this document is prohibited in any form without the written consent of the manufacturing company. The editing of the text, the illustrations, and the paginations were realized by "Cormidi s.r.l." The information and technical data were furnished, checked and validated by the Cormidi Technical Office. The illustrations and technical data included in this manual are non binding: **the manufacturer reserves the right to carry out eventual modifications to its product without notice.**



CORMIDI srl

Via Seude Loc. Fonte
84069 Roccadaspide (SA)

☎ 0828 943689 Fax 0828 943963

💻 www.cormidi.com info@cormidi.com

INTRODUCTION

Dear Customer,

We would like to take this opportunity to thank you for your confidence in us shown by purchasing a CORMIDI Minitransporter. This product was designed and constructed for longevity and to be used with maximum reliability.

*It is, however, **absolutely necessary** to read this manual carefully in which the procedure for optimum use of the equipment is described: improper use may provoke harm to oneself and cause injury to persons and/or to one's health.*

*Therefore, always keep this manual within easy reach so that it may be consulted at any time, before, during, and after use. If the machine is resold, do not forget to give it to the new owner in that inside there is the **EC compliance certificate**.*

We would like to remind you that the illustrations contained in the manual correspond for the most part

to the base model and that our models are regularly improved and perfected with the goal of allowing our customers to enjoy the maximum benefits of innovations in technology: for this reason the characteristics and the information contained in the present manual may have been varied recently. We ask you to contact us in case you should encounter difficulty.

Remember for supplementary information you can always contact your sales representative/dealer, or you can contact us directly by telephone or by email at info@cormidi.com. If there is any doubt, it is better to ask rather than proceed on your own.

We leave you to your perusal of the manual and enjoyment of your machine!

Cordially,

Staff CORMIDI Srl

1. GENERAL INFORMATION

1.1. WARRANTY

Your machine is guaranteed for 24 months from the date of its delivery and includes the substitution of anything in particular that has resulted as, in the opinion of our Technical Office, affected by construction defects.

Any defect in particular that was not caused by the manufacturer, parts used in/on terrain surfaces, and breakdowns caused by incompetence or carelessness, including fueling, are excluded from the guarantee.

The motor, instead, is covered under the manufacturer of the motor's own warranty according to the foreseen conditions and terms.

The guarantee immediately expires if the machine is utilized for uses different from those foreseen by the Manufacturer, if it is damaged by the use of unauthorized accessories or if it is repaired using unsuitable parts.

With the machine a Certificate of Warranty was supplied which outlines the norms which regulate the service of assistance under warranty. We highly recommend reading the **warranty form** to fully understand the various

rights and responsibilities. Collaborate with your sales representative when filling out the form and make sure it is filled out correctly, in that the text and the other formalities (shipment within the time limit, etc.) represent the legal base for the warranty on the machine.

1.2. GOAL OF THE MANUAL

This manual has been drawn up by the manufacturer and is an integral part of the machine: it was written in Italian, the native language of the manufacturer.

The information contained herewithin is addressed to expert operators, equipped with specific knowledge and competence in the sector of use. The manual defines the objectives for which the machine was designed and constructed.

To avoid incorrect manoeuvres that risk accident, it is important to read this manual particularly before the first use to familiarize oneself with the principal commands and their functions.

A constant observance of the information guarantees safety, economy of use, and a longer functional

duration of the machine.

To give a higher prominence to the sections of the text which must not be

ignored, they have been highlighted in bold and preceded with symbols illustrated and defined following here:



READ CAREFULLY: invites a careful and scrupulous reading of the manual before carrying out the operations described.



DANGER: indicate imminently dangerous situations that can provoke serious injury or death if the instructions are not followed.

On the machine potential dangers have been indicated with a sticker characterized by a *red band with white text*.



WARNING: indicates a potentially dangerous situation that can provoke serious injury or death if the instructions are not followed.

On the machine the warnings are indicated with stickers characterized by an orange band with black text.



CAUTION: indicates a potentially dangerous situation that can provoke injury or damage to the machine if the instructions are not followed.

On the machine situations requiring caution are indicated by stickers characterized by a *yellow band with black text*.



PROHIBITED: prohibitions that must be observed by all persons who interact directly and/or indirectly with the machine so that risks may be limited.

1.3. MACHINE DESCRIPTION

The Series 35 machines are manual unloading tracked vehicles that are compact and equipped with a body, designed and manufactured for the exclusive use of transporting inert materials or agricultural products.



READ CAREFULLY: Determine the type of motor that has been installed in your machine accurately, and read its manual to familiarize yourself with it.

To satisfy the various requirements of the market, the machine may be equipped with motors that have similar power but that have different brand names and

characteristics.

1.4. SAFETY INFORMATION



READ CAREFULLY: The information contained here is essential for your safety and for that of your co-workers!

During the production of this machine, every possible measure was taken to make your work safer. Simple prudence, however, is essential: there is no better rule to prevent accidents.



WARNING: The machine must always be operated by a competent and well-trained operator.

- ☞ Carefully read the information before using the machine or before performing maintenance and/or repairs.
- ☞ A few minutes of your time spent reading this manual will save you time and effort later on a.
- ☞ Carefully read the warnings and information written on the signs on the machine and immediately substitute missing or illegible ones. **Respect all regulations contained in these.**
- ☞ The machine was made exclusively for the transport

of inert materials. Any other use is prohibited.



PROHIBITED: It is strictly prohibited to use this machine for the transport of persons and/or animals.



PROHIBITED: It is strictly prohibited to use this machine to tow other machines, vehicles, and/or devices, not even temporarily or in an emergency situation.

- ☞ The machine constitutes a work instrument: always respect the national regulations, especially those relative to safety at the place of work.



REQUIRED: Always wear suitable work clothes and above all suitable work shoes diligently. Always use protective hearing devices.



WARNING: Never wear large or fly-away clothes (scarves, ties) that could easily get caught in the moving parts.

- ☞ It is always advisable to have a first aid kit close at hand.
- ☞ Before turning on the motor, always be sure that there are not any people, animals, or things that could be an obstacle in the work area.



DANGER: Never use the machine inside enclosed areas because the gasses emitted by the exhaust are lethal.



REQUIRED: Carry out the disposal of oils, minerals, and harmful products with respect for the environment and in accordance with the current norms.

- ☞ Every intervention for cleaning, tuning, and/or maintenance must be done under good environmental conditions and with adequate light, **and always with the motor turned off.**



DANGER: Never refuel the vehicle when the motor is on or hot, in the proximity of flames or while smoking. Always keep the machine cleaned of lubricant and/or combustible residues.

- ☞ Pay careful attention to not come into contact with the overheated parts of the motor.



PROHIBITED: It is strictly prohibited to remove protection and safety devices with which the machine is equipped.

- ☞ Avoid working under unsuitable physical conditions or when you are very tired: in these cases interrupt

your work.



DANGER: While working always be sure that the terrain has the required consistency and avoid working on the edge of embankments, ditches, or ravines or on excessively steep or uneven terrain.

- ☞ When putting away the machine take all precautions so that it might not be moved or turned on by incompetent or incapable persons.



CAUTION: Never leave the tool unattended while the motor is on, not even temporarily: when you leave the area, turn off the motor of the machine and put on the parking brake!



DANGER: Never let children play with the machine, not even if it is turned off!

1.5. MACHINE AND MANUFACTURER IDENTIFICATION

The data which identifies the machine and the manufacturer are listed on the aluminium plate that is affixed on the chassis of the machine. The frame number is stamped to the lower part of the frame (see fig. 1).

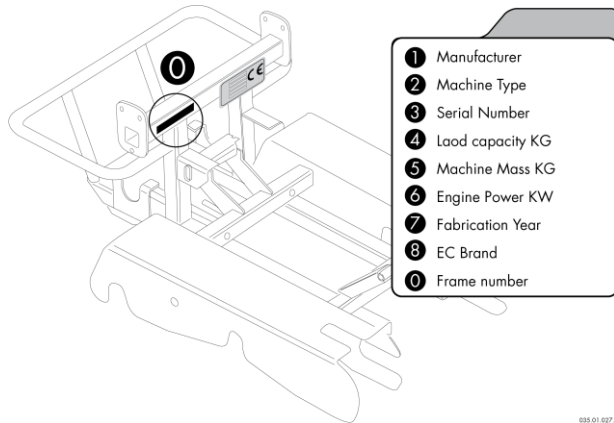
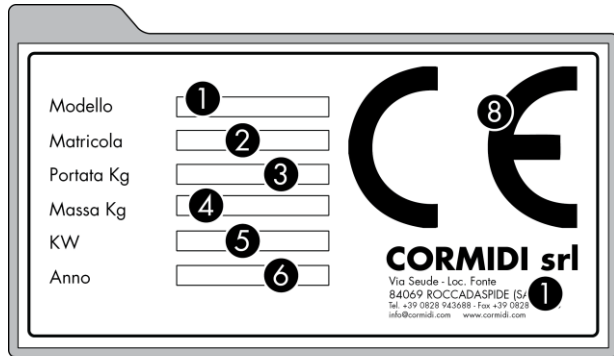

fig. 1 – Identification plate (cod. C1094.14.00)

035 01 027 0

1.6. SAFETY DEVICES



PROHIBITED: it is strictly prohibited to use the machine with its safety devices and protection removed, blocked, or in any way made non functional.



WARNING: Before beginning work, verify the working order of the safety devices and substitute any worn-out and/or broken parts immediately.

1.7. SAFETY TAGS



READ CAREFULLY: During the design phase everything possible was done to prevent eventual risks: where it was technically impossible, specific pictograms were resorted to in order to highlight eventual potential and imminent risks. Specific adhesive tags were made with signals and descriptions associated with pictograms to give a higher im-

portance to possible dangers, in accordance with norms UNI 9244-95 (E).



PROHIBITED: it is strictly prohibited to remove the stickers and the safety plates which the machine is equipped with: immediately substitute deteriorated and/or illegible ones.



fig. 3 – Tag Safety Position

1.7.1. HOT SURFACES

Invites caution in that there is a risk of burning because of the nearness to the hot surface.



fig. 4 (cod. C1094.07.00)

1.7.2. CRUSHING

Tags which indicate a potential risk of crushing that may cause very serious injury or death.



fig. 5 (cod. C1094.09.00)

1.7.3. CUTTING

Tags which indicate a potential risk of cutting that may cause very serious injury or death.



fig. 6 (cod. C1094.09.00)

1.7.4. MOVING PARTS

Nameplate- indicating a potential risk of serious injury for those who operate the machine without guards on moving parts



fig. 6-a (cod. C0900.36.01)

1.7.5. SAFETY DISTANCE



fig. 7 (cod. C1094.02.20)

Tags which alert one to a serious danger of coming near and standing in the field of action of the machine in that there is an imminent risk of danger to self.

1.7.6. PROCEDURE FOR CAUTION

This adhesive which invites caution reminds one to adopt all anti-injury precautions, above all regarding the use of protective devices and individual prevention.



fig. 8 (cod. C1094.04.00)

The meaning of the pictograms is the following:

- Read the manual before turning the machine on for the first time, each time an operator is changed, and in any case in which doubt is raised as to how the machine functions;

- Wear a headset which protects hearing or another device of this type;
- Wear protective gloves of the prescribed type;
- Wear injury-preventive shoes of the prescribed type.

1.7.7. MAXIMUM SLOPES

Completely avoid working on terrains that have latitudinal slopes of more than 10° and longitudinal slopes of more than 20° to avoid the possibility of overturning with serious consequences for the safety of the operator. In every case, but especially in the case of slopes, it is important that the terrain is solid and stable.

1.7.8. PROCEDURE ADDRESSING SLOPES FOR

Sign which indicates in what way one must address the downhill and uphill slopes to avoid serious consequences for the operator and for the machine in that there is the potential danger of overturning.

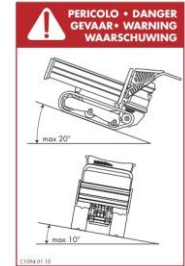

fig. 9 (cod. C1094.01.10)



fig. 9-a (cod. C1094.06.10)

1.7.9. DO NOT TRANSPORT PEOPLE

indicating absolutely not to transport people to avoid serious consequences to the user, the machine and the same people as there is a potential danger of tipping.



fig. 9-b
(cod. C0900.34.01)

1.7.10. MAXIMUM LOAD CAPACITY

Nameplate indicating the maximum transportable load of mini transporter. you must comply with the plate as exceeding the limit you will run into potential risks such as tipping, breakage and the malfunction of the machine.



fig. 9-c
(cod. C0900.35.12)

1.7.11. OTHER TAGS

The label on the side (fig. 12-a) indicates that it is necessary to read the documentation before any intervention, to avoid technical problems (ex. Manual attached to the engine).

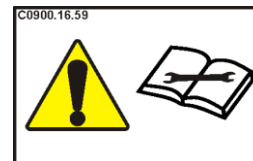

fig. 12-a (cod. C0900.16.59)

The label on the side (fig. 12-b) indicates that you should read the owner's manual before using the devices next to this label, to avoid problems.

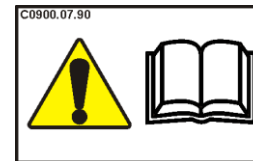

fig. 12-b (cod. C0900.07.90)

1.8. ADMISSIBLE SLOPES

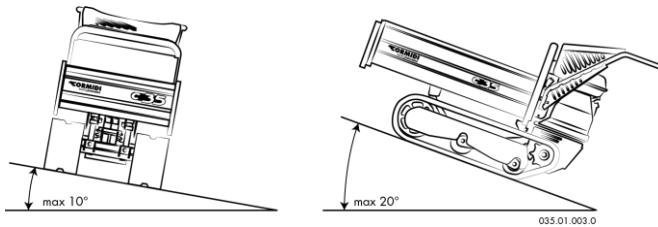

fig. 11 – Maximum admissible slopes

In figure 11 the maximum values for the latitudinal and longitudinal slopes of the terrain are shown on which it is possible to work. These conditions must never be surpassed to avoid the risk of overturning.



DANGER: Always avoid working on terrain with slopes that are greater than those prescribed to avoid the possibility of overturning with possible serious consequences for the safety of the operator.

Always be sure that the terrain upon which you are working or travelling is solid and stable: avoid travelling on excessively soft and/or muddy terrain that can hide snares

and throw the machine off balance, or on loose material that has accumulated that can shift under the weight of the machine.



REQUIRED: The operator has the obligation to assess whether the machine is able or not to deal with a given load path established by the operator himself.

1.9. DIMENSIONS

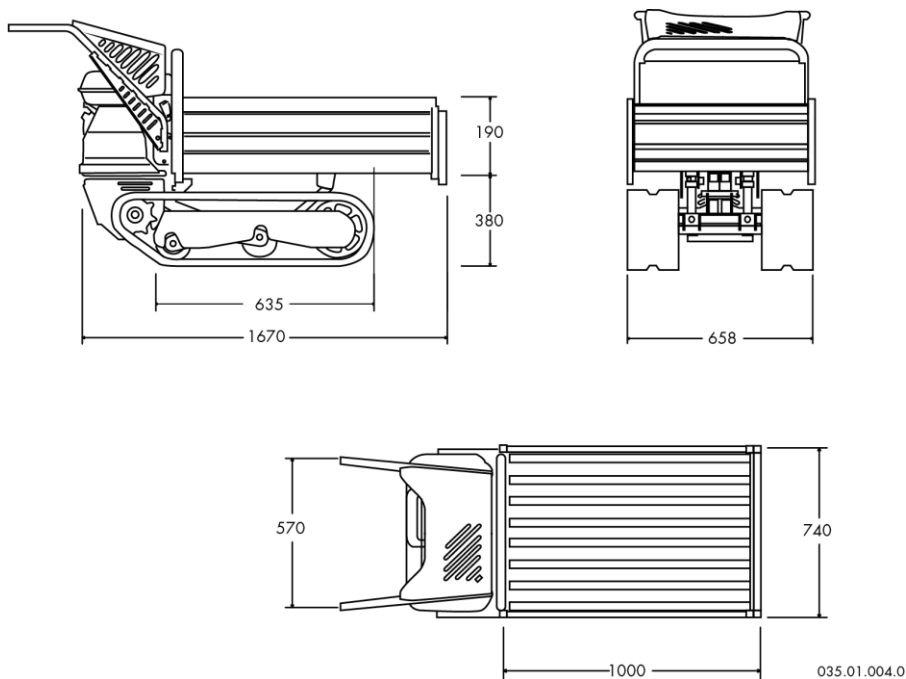

| | | |
|-------------|---------|---------|
| Length | 1670 mm | |
| Width | 740 mm | |
| Wheel Track | 658 mm | |
| Height | Min | 920 mm |
| | Max | 1080 mm |

fig. 12 – Dimensions

1.10. TECHNICAL DATA

CORMIDI C40

| | |
|--------------------------|--------------------------------------|
| Model | Mechanical Minidumper |
| Type | 5.40 |
| Mass [Kg] | 195 |
| Engine | Petrol |
| Power [kW] - (cv) | [3.6] (4.8) |
| Max speed [m/s] - (km/h) | 0,6 (2,2) 1,1 (3,9) |
| Load Capacity[kg] | 400 |
| Start-up | Pull-start |
| Accelerator | Manual command lever |
| Transmission | Mechanical |

Continuous Equivalent Pondered Acoustic Power level A **LpA= 100 dB(A)**

Continuous Equivalent Pondered Acoustic Power level A (assured) **LwA= 101 dB(A)**

Vibration level **m/s²** on the arms: ≤ **2,5 m/s²**
on the body: ≤ **1,1 m/s²**

035.01.051.0

1. CONTROL LEVERS

DRIVE LEVER (LEFT)

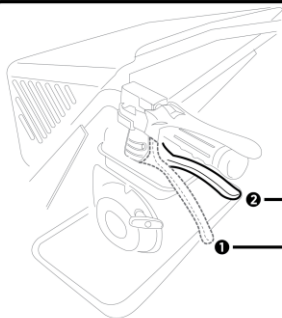

LEVER OPERATED
THE TRACK LEFT STOPS, THE
MACHINE ROTATES TO THE LEFT

LEVER NOT TURNED
THE LEFT TRACK IS NOT LOCKED

035.01.031.0

ALLOWS TO TURN LEFT

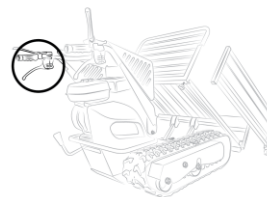
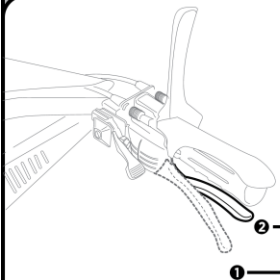

fig.13 Control lever left track

DRIVE LEVER (RIGHT)



LEVER OPERATED
THE TRACK RIGHT STOPS, THE
MACHINE ROTATES TO THE RIGHT.

LEVER NOT TURNED
THE RIGHT TRACK IS NOT LOCKED

035.01.032.0

ALLOWS TO TURN RIGHT

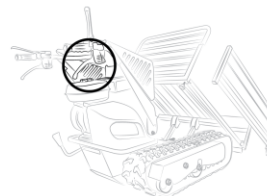
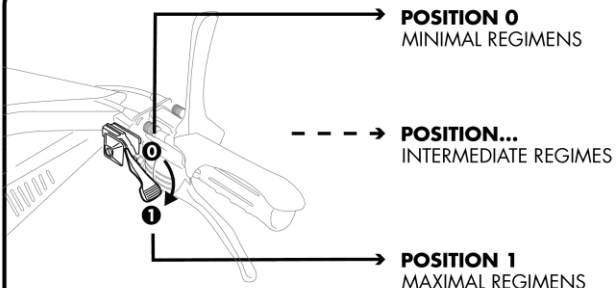

fig.14 Control lever right track

ACCELERATOR



035.01.034.0

ALLOWS VARIATIONS IN THE ROTATION REGIMEN OF THE MOTOR TO OBTAIN THE REQUIRED POWER.



fig.16 Accelerator control lever

GEAR LEVER

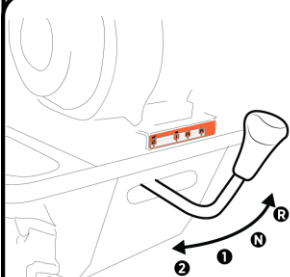

- R**
REVERSE
- N**
NEUTRAL
- I**
FIRST GEAR
- II**
SECOND GEAR

035.01.035.0

GEAR SELECTOR (I, II, N, R)

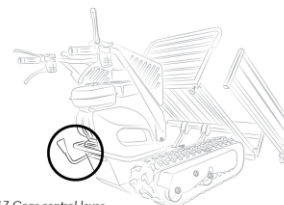
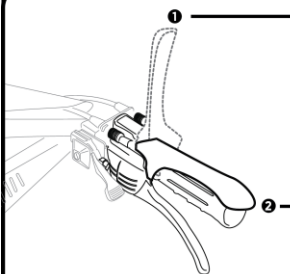

fig.17 Gear control lever

CLUTCH LEVER



1 → **LEVER NOT TURNED**
THE MACHINE DOES NOT MOVE

2 → **LEVER OPERATED**
THE MACHINE MOVES

035.01.036.0

THE RELEASED LEVER ACTUATES THE ROTATION OF THE TRACKS.

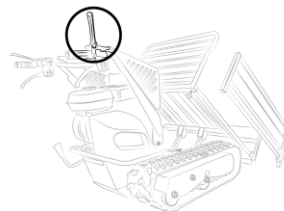

fig.18 Clutch control lever

2. INSTRUCTIONS FOR USE

2.1. FIRST USE



READ CAREFULLY: before using the machine you must read all of the instructions in this manual and the user's and maintenance manual of the motor installed on your machine scrupulously. Furthermore, always keep it attached to the machine..

The machine is normally delivered completely assembled and ready for use with an empty fuel tank.

Fill the fuel tank, open the fuel tap and follow the start-up procedure described in the appropriate paragraph.

2.2. BREAKING-IN PERIOD

The technology used during the construction of your machine does not require a break in period. However, during the first period of use, it is necessary to use these precautions:

- ☞ During the first 50 hours, avoid using the motor at over 70 % of the total power.



READ CAREFULLY Read the user's manual and the maintenance manual for the motor installed in your machine carefully and follow the instructions prescribed for its own break in period.

- ☞ During the first period of use, the tracks undergo an adjustment, for which it is necessary, after the first 50 hours of operation, to carry out the regulation of the tension of the tracks.

2.3. MOTOR START-UP

Every time you wish to start up the motor, always verify and adhere to the following indications scrupulously:

- Always start up the motor outside and be certain that there are no other persons in the vicinity of the machine and/or other impediments.
- Check that there is fuel in the tank and, if necessary, add some.



WARNING: Before starting the engine, make sure you have the transmission in neutral, right upper lever fully released (see fig.16-17) to avoid eventual movement of the machine that could present safety issues for the operator. Do not make sharp turns with the engine

at high rpm, especially in second gear, danger breaking transmission.

- Follow the specific procedure prescribed by the constructor of the motor shown in the attached instructions.

When the motor is hot, in petrol operated motors, avoid inserting the starter.

2.4. REFUELING



DANGER: Refuelling must always be done with the motor turned off! Do not smoke while refuelling or while handling fuel to avoid the risk of fire!

Refuelling and /or movement of the fuel from one container to another must always be done outside, always from fires or from other heat sources. Always check that the type of fuel is the correct one, specified for the motor of your machine.

- Position the machine on a clean surface.
- Unscrew the plug slowly.
- Pour the fuel into the tank slowly.
- Screw the plug on again tightly.
- Immediately dry any fuel spills.



WARNING: Start up the motor only after having made certain that there are no traces of fuel that have accidentally spilled out!



WARNING: The conservation of the fuel must always be done with respect for the specific laws, in suitable places, away from sources of heat, and with clean, well closed suitable containers!



REQUIRED: Avoid the dispersion of fuel and/or fuel containers in the environment. Carry out the disposal according to the current laws and with respect for the environment.

2.5. DRIVING THE MACHINE



WARNING: Where possible, try to avoid travelling on rocky or icy terrain, on rails and railway sections because they may damage the tracks and reduce their longevity. Also avoid passing over material that could ruin the tracks, such as sharp objects, pieces of metal, etc. that could get caught up in the tracks and provoke a break.



DANGER: Always avoid overloading the machine above the prescribed limits: during movement, an overload could create structural variations that were not foreseen and could provoke the overturning of the machine with serious safety consequences.

At the start-up, regulate the number of rotations of the motor to the desired level by activating the accelerator lever, according to the required power (when the machine is loaded, you must bring the lever above the halfway mark between the minimum and maximum).

Under certain conditions, especially when the machine is loaded or going uphill, a loss of engine power may occur because of a motor overload; this may also cause it to shut down

2.5.1. DRIVING POSITION

Your machine is driven manually and its speed and stability are operated with the feet.

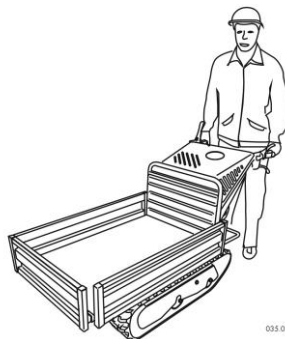

035.01.011.0

fig. 28 – Driving position

When the machine is in gear, always grasp the stronghold handle firmly

Never release the handles.



DANGER: When the machine is in gear, the operator must always maintain the prescribed driving position and must avoid letting the machine advance without a driver.

Never speed when working, rather proceed at a speed adjusted to your walking speed, in this way you will maintain a safe control over the commands.

2.5.2. FORWARD GEAR

To allow the machine to advance one must activate both drive levers simultaneously by pushing down

Avoid addressing downhill slopes in forward gear, refer to the paragraph “*Travelling on Slopes*”.

2.5.3. REVERSE GEAR

To allow the machine to be back into reverse and lower both red levers..

Avoid addressing uphill slopes in reverse gear, especially with a loaded machine, rather follow the procedure described in the paragraph “*Travelling on Slopes*”.



DANGER: While in reverse gear, always check to see that there are no obstacles and/or persons in the vicinity.

2.5.4. TRAVELLING ON SLOPES

When addressing sloped segments, especially when the machine is loaded, one must use this particular technique:

- ☞ Always address uphill slopes in forward gear;
- ☞ Always address the downhill slopes in reverse gear.

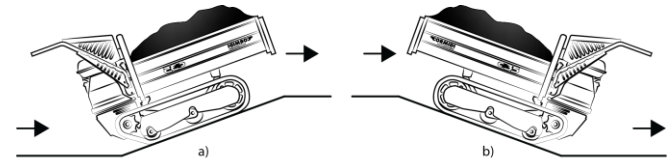

fig. 29– a) going uphill; b) going downhill



DANGER: Completely avoid working on terrains that have lateral slopes of more than 10° and longitudinal slopes of more than 20° to avoid the possibility of overturning with serious consequences for the safety of the operator.

On high slope ground is necessary to work with high regimen of motor (as the slope) minimizing the opening of drive levers (see p.14); otherwise could be verify cavitation problems and missing the “engine-brake” effect: if the machine increase the speed “alone”, release the drive levers.

2.5.5. FAST GEAR

Using the fast gear allow to increase the transportation speed of the machine, to the detriment of torque and of starting power or to address slopes and maneuvers, especially when the machine is loaded.

It's necessary to restrict the use of fast gear only for travelling on plain and not uneven ground, without obstacles.

2.5.6. STOPPING MOVEMENT

To stop the movement has slowly release the red lever located on the right.

Do not release the red lever to the right with the engine at full throttle, the danger of sudden braking..

2.5.7. MOVEMENT IN CURVES

To To allow the machine to perform the curves operate the lever on the side towards which it intends to bending:

- To turn right actuate the right guide;
- To turn left, move the lever to the left guide.

The steering is determined by the slowing of the speed of one track over another. Consequently, the speed and the degree of steering angle are proportional to the intensi-

ty of pressure with which act on each lever.



PROHIBITED: It is strictly prohibited to surpass the carrying limits indicated in the table on page 9.

2.6. TRANSPORT LOAD

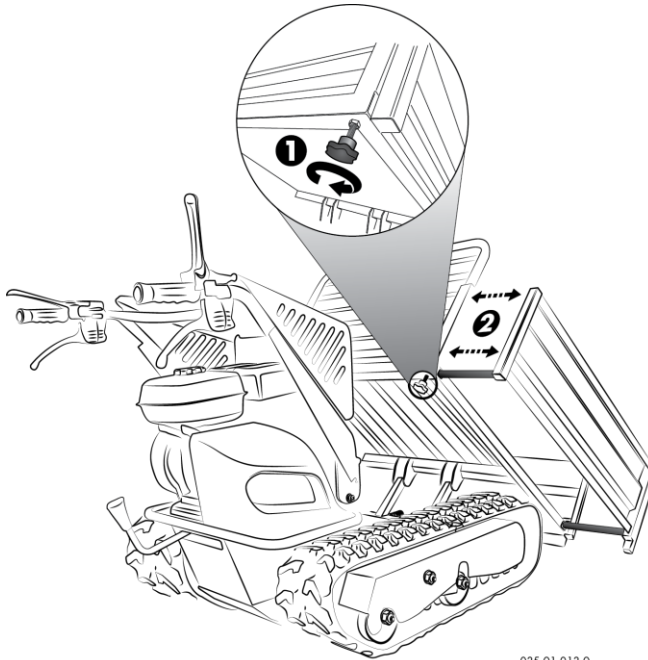

fig. 33 - opening side

035.01.013.0

- Loosen the knob "1";
- pull on the side of "2" (MAX 150 mm / 5.9 in)
- Tighten the knob "1"
- Repeat this step on the other side;
- Repeat this step on the front;
- Make sure that the side may be locked and you have the load so that it cannot fall.



WARNING - Ensure you secure the load on the skip, otherwise the vehicle may overturn and be unstable when driving. The box is not suitable for the carriage of inert material.



PROHIBITED: it is absolutely forbidden to walk with the load on an incline!

2.7. UNLOADING MATERIAL

Your machine is equipped with a mechanical dumping device for the body which allows the unloading of the material.

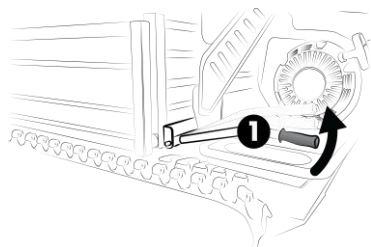

035.01.019.0

fig. 34 – Closing dump

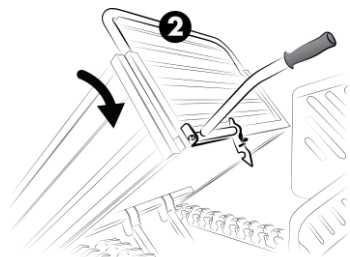

035.01.020.0

fig. 35 – Bed tipping

2.7.1. UNLOADING THE BODY



WARNING - Before unloading, be certain that the terrain is flat, solid and compact. Carry out the dumping manoeuvre slowly and uniformly. Do not move forward with the machine during the dumping phase.

To carry out the dumping manoeuvre:

- Position yourself on a level, solid, and compact surface or terrain;
- Remove the front wall (see Fig. 33) by unscrewing the knob;
- Pull up on the lever "1" to cause the overturning of the box and manual unloading of the material;
- Push down on the body by applying pressure manually at the point 2 up to bring the locking system in its place;



CAUTION: During the unloading, if the body hits up against an obstacle, avoid moving the machine forward: this could damage the connecting points of the body!



PROHIBITED: It is strictly prohibited to travel if the body is not in its resting position.

2.8. TRANSPORT

If the machine needs to be transported, one must proceed correctly to avoid dangers to persons and/or to the machine. Given the weight of the machine, it is not possible to move it manually. Thus, it is necessary to use suitable means of lifting to load it onto a means of transport.

Minimum requirements lifting straps:

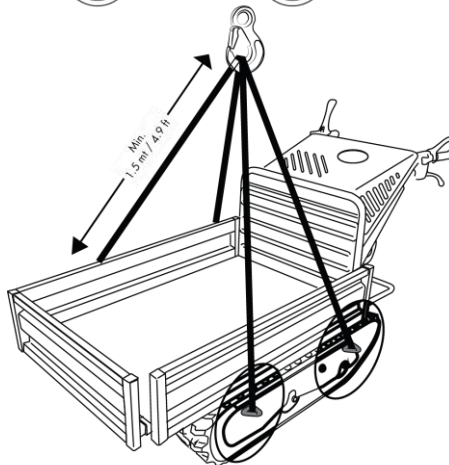

035.01.014.0

fig. 36 – Anchoring points to lift machine

To carry out this operation under the safest conditions possible, proceed as follows:

- Empty the fuel tank and close the plug;
- Fix the lifting hooks exclusively to the anchoring points that were prescribed by the manufacturer;
- Fix it firmly to the surface of the means of transport pulling down firmly, and always connecting the points indicated in the figure.

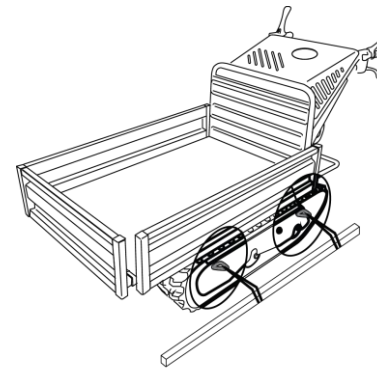

035.01.015.0

fig. 37 – Anchoring points for transportation



WARNING: Use 4 strips of equal length and lifting capacity. Features required for each band: lifting capacity 200 kg, minimum length of 1.5 m / 4.92 ft with its cricket safety.



WARNING: During transport, always position the machine levelly to avoid the spilling of oil or other liquids.



WARNING: Raise the machine by hooking it exclusively to the hooks predisposed for this: the anchoring of the machine in other points can cause breakage with the consequent fall of the machine and can cause serious harm to persons.

2.9. STORAGE

Whenever the machine must remain inactive for several months, it is necessary to provide a correct garaging so that the machine is in perfect working order when it is used again.

Carry out the storage by following all of these instructions:

- Carry out all necessary repairs
- Empty the fuel tank completely
- Proceed with a careful cleaning and remove all ce-

ment, mud, and/or organic residues carefully;

- Proceed with all operations regarding the motor that are described in its own manual
- Carry out a greasing of all points listed in the specific chapter;
- Place the machine in such a way that it is sheltered from atmospheric agents under stable conditions and on a flat surface;

When the machine is put back into service, you must once again carry out the greasing in all points specified by the relative chapter. Proceed with all operations regarding the motor that are described in its manual and check the oil level and, if necessary, add some.

3. MAINTENANCE



DANGER: always carry out all maintenance operations with the motor off and with the ignition switch in the “0” position.

A good maintenance is necessary and is the secret to obtaining low running costs, to lengthening the life of your machine, and to always maintaining it at its highest efficiency.

Beyond the normal maintenance operations on the mechanic and hydraulic parts, it is a good rule to carry out a periodic washing of the machine and to proceed with a careful cleaning to take away all cement and/or mud residues that have been deposited. After every wash it is necessary to grease all of the parts that are subject to friction, as specified in the paragraph “Greasing”.

3.1. MAINTENANCE INTERVALS

To maintain the highest level of efficiency, it is necessary that the maintenance be carried out at regular programmed intervals.

In the following table a summary of the maintenance operations is listed that are to be carried out periodically.

() Maintenance and adjustment table

| | |
|--|-----------------|
| EVERY 8 HOURS  | |
| CLEANING | MACHINE |
| GREASING | ROCKING ROLLERS |
| VERIFY (1) | MOTOR OIL |

| | |
|---|------------|
| EVERY 50 HOURS  | |
| ADJUSTMENT | TRACKS |
| CLEANING (1) (2) | AIR FILTER |

| | |
|---|-----------|
| see maintenance manual Honda use | |
| SUBSTITUTION (1) | MOTOR OIL |

(1)
CHECK WITH THE ATTACHED MANUAL FOR THE MOTOR

(2)
IN DUSTY AREAS YOU MUST INCREASE THE FREQUENCY

033.01.0294.0

3.2. MOTOR.



REQUIRED: When changing the motor oil, always use a suitable aspirator to remove old oil. Avoid the dispersion of oil and filters in the environment and carry out their disposal with respect for the environment and the regulations in force.

3.3. TRACKS

Registration

Every 200 hrs Register the tension of the tracks.

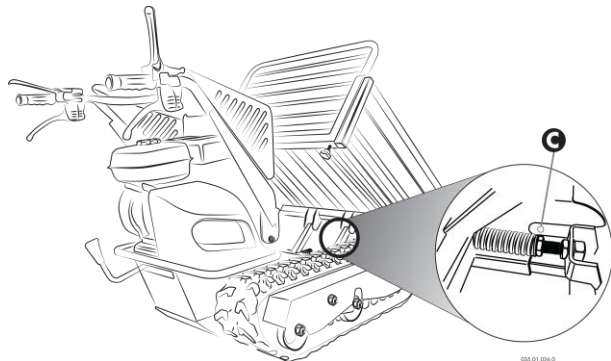

fig. 38 - Regulation track tension

The correct tension of the tracks is important in order to guarantee their longevity and for your own safety: to check it, apply a pressure of 2 kg on the track and check that the arrow is at about 30mm.

To perform the adjustment of the tension of the tracks in the correct way:

- Adjust the tension acting on the nut "C";
- Check that the arrow is 30 mm;
- Repeat the same steps for the other track.

The preload spring should be between 80-85 mm.

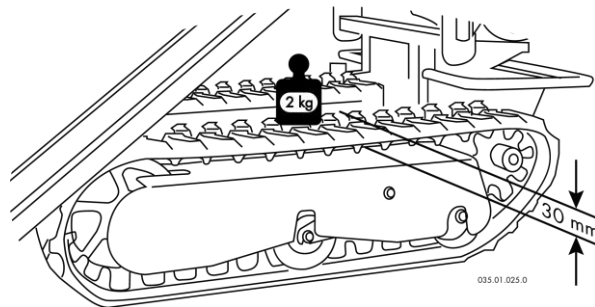

fig. 39 - Check track tension

Substitution



DANGER: Never work with the machine raised on a jack or suspended, rather always place it upon suitable trestles that can maintain the weight of the machine before starting work.

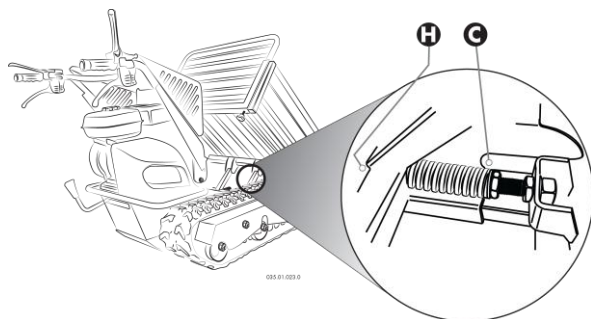

fig. 41 - Substitution of the track

For the substitution of the tracks, proceed as follows:

- Raise the side of the machine on which you wish to work using hydraulic jacks or a crane;
- Position the machine on suitable trestles, and check to see that it is stable;
- Use of two keys, completely unscrew the nut "C" and

completely screwed down nut "H", in this maneuver simultaneously screwing the track of the right and the left track in order to bring forward the frame uniformly

- Remove the track "E" starting from the front;
 - Mount the new track making it fit in the teeth of the drive wheel "F";
 - Be fit the front of the idler wheel on the track "G";
 - Adjust the tension acting on the nut "C" (see fig.39)
 - Check that the arrow is 30 mm (see fig.40)
- After the adjustment, lock nut

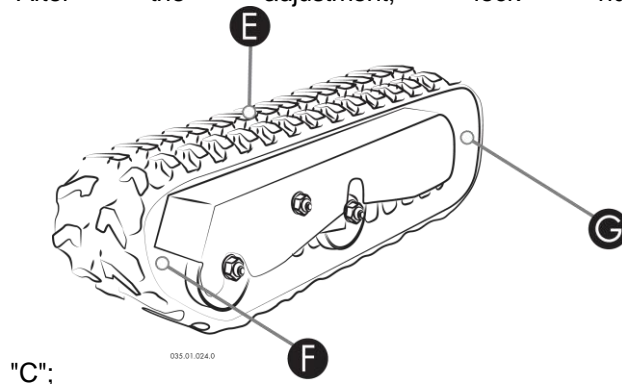
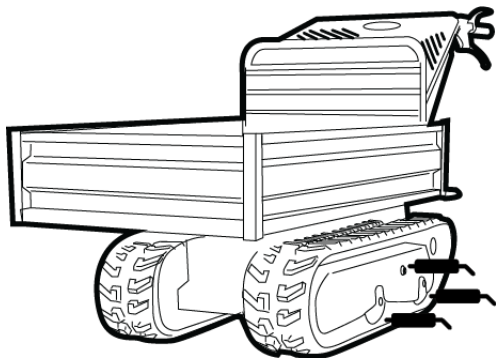

fig. 42 - Mounting track

3.4. GREASING

Every 8 hrs

Refurnish the grease in all prescribed points.



035.01.018.0

fig. 41 – Greasing Points

Refurnish the grease in all prescribed greasing points, using a suitable grease.



DANGER: If the machine works in marine areas clean and grease thoroughly in all its points every 8 hours.

3.5. RECOMMENDED LUBRICANTS

| | Type | Quantity |
|-----------|---|----------|
| Motor Oil | View user and maintenance Honda | |
| Grease | MR Filante | |

4. TROUBLESHOOTING

| Fault | Possible Causes | Solution |
|---|---------------------------------------|---|
| The machine moves downhill | Transmission failure (belt / pulley). | minitransporter bring in a mechanical workshop with specific skills |
| | Track tension is incorrect. | Restored to the correct tension |
| | Tracks broken or damaged. | Replace the tracks |
| Excessive noise from the tracks during movement | Bearing failure or rollers. | minitransporter bring in a mechanical workshop with specific skills |
| | Poor lubrication rollers | Lubricate stakeholders |
| | Broken rollers or ball bearings | minitransporter bring in a mechanical workshop with specific skills |

| Fault | Possible Causes | Solution |
|--|----------------------------------|--|
| Excessive noise during the rotation of the barrel. | Not enough grease. | Grease |
| | Breakdown in the bearings | Have the machine repaired by a mechanic |
| The accelerator does not respond. | The accelerator cable is broken. | Replace the cable at a mechanic's. |
| The motor does not work correctly or makes an excessive amount of noise. | Various causes. | Have the motor looked at by a mechanic who has expertise in this area. |
| The motor does not develop power. | The air filter is blocked | Replace the air filter |
| | Various causes | Have the motor looked at by a mechanic who has expertise in this area |
| The motor will not start. | Not enough fuel | Refuel the machine |

6. INDEX

| | | | | | |
|---|----|--|---------------------------|-----------------------------|--------|
| Admissible Slopes..... | 9 | Identification of - | 4 | Slopes | |
| Body | | Machine Description..... | 2 | Travelling on - | 19 |
| Unloading the - | 22 | Maintenance Intervals..... | 25 | Speed | |
| Breaking-in Period | 16 | Manual, Goal of the - | 1 | Fast | 20 |
| Comandi..... | 12 | Manufacturer, Identification of - | 4 | Stopping Movement | 20 |
| Devices | | Motor | | Storage..... | 24; 25 |
| Safety | 5 | Maintenance..... | 26; <i>See Attachment</i> | Substitution | |
| Dimensions | 10 | Motor Start-up..... | 16 | Traks | 27 |
| Driving | | Movement in Curves | 20 | Tag | |
| Position | 18 | Other Tags | 8 | Identification | 4 |
| the Machine..... | 17 | Recommended Lubricants..... | 28 | Safety..... | 5 |
| Fast Gear | 20 | Refueling | 17 | Targhetta di Sicurezza | |
| First Use | 16 | Registration | | Marcia sulle Pendenze | 8 |
| Forward Gear..... | 19 | Traks | 26 | Technical Data | 11 |
| Gear | | Reverse Gear | 19 | Traks | 26 |
| Forward | 19 | Safety | | Registration..... | 26 |
| Reverse | 19 | Devices | 5 | Substitution | 27 |
| GENERAL Information | 1 | Information | 3 | Transport | 23 |
| Goal of the Manual | 1 | Tag Caution..... | 7 | Registration..... | 26 |
| Greasing | | Tag Crushing | 6 | Substitution | 27 |
| Points of - | 28 | Tag Cutting | 6 | Transport | 23 |
| Identification Manufacturer and Machine | 4 | Tag Hot Surfaces | 6 | Transport | 23 |
| Identification Tag | 4 | Tag Maximum Slopes | 7 | Transporting Loads..... | 20 |
| Instruction for Use..... | 15 | Tag Procedure for Addressing Slopes..... | 7 | Travelling on Slopes..... | 19 |
| Introduction | II | Tag safety Distance | 7 | Troubleshooting | 29 |
| Machine | | Tags | 5 | Unloading Material..... | 22 |
| | | | | Unloading the Body..... | 22 |
| | | | | Use | |
| | | | | Instruction for - | 15 |
| | | | | Warranty..... | 1 |

7. SUMMARY

| | | | |
|---|----|-----------------------------------|----|
| Introduction..... | II | 2. Instructions for Use..... | 15 |
| 1. General Information..... | 1 | 2.1. First Use | 16 |
| 1.1. Warranty..... | 1 | 2.2. Breaking-in Period | 16 |
| 1.2. Goal of the Manual | 1 | 2.3. Motor Start-up | 16 |
| 1.3. Machine Description..... | 2 | 2.4. Refueling | 17 |
| 1.4. Safety Information | 3 | 2.5. driving the Machine | 17 |
| 1.5. Machine and Manufacturer Identification..... | 4 | 2.5.1. Driving Position..... | 18 |
| 1.6. Safety Devices | 5 | 2.5.2. Forward Gear..... | 19 |
| 1.7. Safety Tags..... | 5 | 2.5.3. Reverse Gear | 19 |
| 1.7.1. Hot Surfaces | 6 | 2.5.4. Travelling on Slopes | 19 |
| 1.7.2. Crushing | 6 | 2.5.5. Fast Gear | 20 |
| 1.7.3. Cutting..... | 6 | 2.5.6. Stopping Movement..... | 20 |
| 1.7.4. moving parts | 6 | 2.5.7. Movement In Curves..... | 20 |
| 1.7.5. Safety Distance | 7 | 2.6. TRANSPORT LOAD | 21 |
| 1.7.6. Procedure for Caution | 7 | 2.7. Unloading Material | 22 |
| 1.7.7. Maximum Slopes | 7 | 2.7.1. Unloading the Body | 22 |
| 1.7.8. Procedure for Addressing Slopes | 7 | 2.8. Transport | 23 |
| 1.7.9. Do not transport people..... | 8 | 2.9. Storage | 24 |
| 1.7.10. Maximum load capacity | 8 | 3. Maintenance | 25 |
| 1.7.11. Other Tags | 8 | 3.1. Maintenance Intervals | 25 |
| 1.8. Admissible Slopes | 9 | 3.2. Motor..... | 26 |
| 1.9. Dimensions..... | 10 | 3.3. Tracks..... | 26 |
| 1.10. Technical Data..... | 11 | 3.4. Greasing | 28 |
| 1. control levers | 12 | 3.5. Recommended Lubricants..... | 28 |

4. Troubleshooting 29
7. Summary 32

| | | | |
|---|--|--|--|
|  | | CORMIDI S.R.L. VIA FONTE 342 84069 - ROCCADASPIDE - SALERNO TEL.: +39 0828.943688 - FAX: +39 0828.943963 | |
| <u>DICHIARAZIONE CE DI CONFORMITA'</u> <u>EC DECLARATION OF CONFORMITY</u> | | | |
| Il sottoscritto, detentore della documentazione tecnica, dichiara che la sottoindicata macchina è stata progettata e costruita in conformità alle seguenti Direttive Europee, come emendate, alle norme armonizzate citate e ai decreti e regolamenti che le traspongono nelle leggi nazionali. The undersigned, holder of the technical documentation, declares that the machine described below has been designed and manufactured in compliance with the following European Directives, as amended, the European Standards and the regulations transposing them into national laws. | | | |
| 1. 2004/42/CE "SICUREZZA DELLE MACCHINE/SAFETY OF MACHINERY" | | | |
| 1.1 NORME EUROPEE ARMONIZZATE NEL CUI RIPETO LA CONFORMITA' E DICHIARATA: EUROPEAN HARMONISED STANDARDS UNDER WHICH CONFORMITY IS DECLARED: EN 474-1:2004 + X EN 474-2:2004 + X EN ISO 3471 X EN ISO 10218-1 X A1:2007 A1:2007 | | | |
| 1.2 PRINCIPALI COMPONENTI DI SICUREZZA MONTATI E FORNITI CON LA MACCHINA MAIN SAFETY COMPONENTS INSTALLED AND SUPPLIED WITH THE MACHINE | | | |
| 1.2.1 VARIANTE PER LA MOVIMENTAZIONE DEI CARICHI SOGGETTI OBJECT HANDLING APPLICATION KIT [EN 474-5 PUNTI 4.1.7.3-4] X | | | |
| 1.2.2 STRUTTURA DI PROTEZIONE CONTRO LA CADUTA DEGLI OGGETTI (C.O.P.) FALLING OBJECT PROTECTIVE STRUCTURE (F.O.P.S.) X | | | |
| 2. 2000/14/CE "EMISSIONE ACUSTICA/NOISE EMISSION" | | | |
| 2.1 PROCEDURA DI VALUTAZIONE DELLA CONFORMITA' E CONFORMITY ASSESSMENT PROCEDURE FOLLOWED | | ALLEGATO VI (ART. 4/1) | |
| 2.2 NOME ED INDIRIZZO DELL'ORGANISMO NOTIFICATO NAME AND ADDRESS OF THE NOTIFIED BODY | | ECO CERTIFICAZIONE SPA (N. 0714) - BALT VIA MENCORANA, 33 - FAENZA (RA) | |
| 2.3 LIVELLO DI POTENZA SONORA MISURATO MEASURED SOUND POWER LEVEL L _{WA} (dB(A)) | | 100 dB (A) | |
| 2.4 LIVELLO DI POTENZA SONORA GARANTITO (L _{WA} (E)) GUARANTEED SOUND POWER LEVEL L _{WA} (E) (dB(A)) | | 101 dB (A) | |
| 2.5 POTENZA NETTA IN USCITA (COME DEFINITA DALLA DIRETTIVA 97/48/CE) ENGINE NET OUTPUT (AS DEFINED BY THE EUROPEAN DIRECTIVE 97/48/CE) | | 4.1 kW | |
| 3. 2004/108/CE "COMPATTAZIONE ELETTRICAMENTE/ ELECTROMAGNETIC COMPATIBILITY" | | | |
| 3.1 NORME EUROPEE ARMONIZZATE IN CUI RIPETO LA CONFORMITA' E DICHIARATA EUROPEAN HARMONISED STANDARDS UNDER WHICH CONFORMITY IS DECLARED | | EN 13309:2000 | |
| 4. ALTEZZA MASSIMA PERICOLOSA/ MAXIMUM DANGEROUS HEIGHT | | | |
| APPLICABILI/OTHER | | APPLICABLE DIRECTIVE/S: | |
| 5. COEFFICIENTE DI RUMORE/ NOISE COEFFICIENT | | | |
| CORMIDI S.r.l. - Via Fonte 342 - 84069 - RoccaDasPide - Salerno | | | |
| 6. MACCHINA/ MACHINE | | | |
| autoribaltabile a cingolo compatto /Crawler | | | |
| 7. TIPO/TYPE | | 8. MATRICOLA N°/SERIAL N° | |
| C-6.60 DHE | | | |
| 9. ANNO DI COSTRUZIONE/CONSTRUCTION YEAR | | | |
| 2010 | | | |
| 10. PERSONA ABBONZATA A COSTRUIRE IL FASCICOLO TECNICO/PERSON AUTHORIZED TO COMPILE THE RELEVANT TECHNICAL DOCUMENTATION | | | |
| ARMANDO CORMIDI - VIA FONTE, 342 - 84049 ROCCADASPIDE (SA) | | | |
| DICHIARAZIONE N° <input type="text"/> | | | |
| ROCCADASPIDE | | | |