

Honda Lawn Mower HRU216M1 Owner's Manual & Service Record Booklet



Read and understand this Owners Manual before operating the Lawnmower

Thank you for purchasing a Honda lawn mower.

This manual covers the operation and maintenance of the Honda HRU216 lawn mower.

We want to help you get the best results from your mower and to operate it safely. This manual contains the information on how to do that; please read it carefully.

This manual should be considered a permanent part of the lawn mower and should remain with it, if it is resold.

If you have a problem or questions concerning the mower, contact your supplying dealer.

SAFETY MESSAGES

Pay special attention to statements preceded by the following words:

 **DANGER** You WILL be KILLED or SERIOUSLY HURT if you don't follow instructions.

 **WARNING** You CAN be KILLED or SERIOUSLY HURT if you don't follow instructions.

 **CAUTION** You CAN be HURT if you don't follow instructions.

Each message tells you what the hazard is, what can happen, and what you can do to avoid or reduce injury.

DAMAGE PREVENTION MESSAGES

You will also see other important messages that are preceded by the following word:

 **NOTICE** Your lawn mower or other property can be damaged if you don't follow instructions.

The purpose of these messages is to help prevent damage to your lawn mower, other property, or the environment.

Do not use this lawn mower except for mowing.

Illustrations in this manual are for instructional purposes only and may not be exact representations. All information contained in this manual is based on the latest product information available at the time of publication. Honda Australia Motorcycle and Power Equipment Pty. Ltd. reserves the right to make changes at any time without notice. No part of this publication may be reproduced, stored in a retrieval system, or transmitted in any form by any means, electronic, mechanical, photocopying, recording, or otherwise, without the prior written permission of Honda Australia Motorcycle and Power Equipment Pty. Ltd. This includes text, figures and tables.

Honda Australia Motorcycle and Power Equipment Pty. Ltd.

ABN 96 006 662 862 (trading as Honda MPE).

CONTENTS

1. WARRANTY.....	4
Honda Limited Warranty.....	4
2. SAFETY INSTRUCTIONS.....	5
3. COMPONENT IDENTIFICATION.....	7
4. CONTROLS.....	9
Fuel Valve.....	9
Throttle Lever.....	9
Blade Control Lever.....	10
Drive Clutch Lever.....	11
Cutting Height Adjustment Lever.....	12
Shift Lever.....	13
Front Guard.....	14
5. PRE-OPERATION CHECKS.....	15
ARE YOU READY TO MOW?	15
CHECK YOUR LAWN.....	15
CHECK YOUR MOWER.....	16
Blades.....	16
Engine Oil Level.....	19
Fuel.....	20
Air Cleaner.....	21
Grass Bag	21
Cutting Height.....	23
6. OPERATION.....	24
MOWING PRECAUTIONS.....	24
STARTING THE ENGINE.....	24
Throttle Lever.....	25
Blade Control Lever.....	27
Drive Clutch Lever.....	28
Shift Lever.....	29
STOPPING THE ENGINE.....	30

CONTENTS - continued

SAFE MOWING PRACTICES.....	31
MOWING TIPS.....	33
7. TRANSPORTING/STORAGE.....	36
BEFORE LOADING.....	36
LOADING AND UNLOADING.....	36
STORAGE PREPARATION.....	37
Handlebar Folding.....	40
STORAGE PRECAUTIONS.....	41
8. MAINTENANCE.....	42
THE IMPORTANCE OF MAINTENANCE.....	42
MAINTENANCE SAFETY.....	43
MAINTENANCE SCHEDULE.....	44
ENGINE MAINTENANCE.....	45
Engine Oil Change.....	45
Engine Oil Recommendations.....	46
Air Cleaner Service.....	47
Spark Plug Service.....	48
Carburetor Modification for Altitude operation.....	50
Fuel Recommendations.....	50
BLADE REMOVAL & INSTALLATION.....	51
GRASS BAG CLEANING & REPLACEMENT.....	56
9. TROUBLESHOOTING.....	57
10. SPECIFICATIONS.....	59
11. SET-UP INSTRUCTION.....	62
12. SERVICE SCHEDULE SHEET.....	64

1. HONDA LIMITED WARRANTY

Honda* warrants each new Honda lawn mower to be free from defects in material and workmanship for the period detailed on your warranty registration form.

The Honda warranty is limited. In order to qualify, the service schedule sheets located at the back of this manual must be completed (page 64). Any Authorised Honda Lawnmower Dealer will repair any part that proves defective within the limits of this warranty at no charge to the owner for parts and labour. All parts replaced under this warranty become the property of Honda. Transportation costs for the product either to or from the dealer are the responsibility of the owner.

This warranty will not apply to:

- Any part which has been subject to misuse, negligence, accidental damage, improper or inadequate maintenance, or improper storage.
- Repairs rendered necessary by or arising from, the use of other than genuine Honda parts.
- Normal maintenance items, including but not limited to adjustment and cleaning of carburetor, fuel strainer and air filter.
- Normal replacement of service items, including but not limited to spark plug, air filter and cutting blades.
- Deterioration of any item due to normal use, fair wear and exposure unless due to a defect in material or workmanship.
- Any work or adjustment performed by persons other than Authorised Honda Lawnmower Dealers, or damage resulting therefrom.

The benefits conferred by this warranty are in addition to all other rights and remedies in respect of the product which the purchaser has under the Trade Practices Act 1974 and/or any relevant State or Territory Acts. Where permitted, the liability of Honda shall be limited at its option to the repair or the replacement of the mower.

***Honda is:** Honda Australia Motorcycle and Power Equipment Pty. Ltd.
ABN 96 006 662 862 Private Bag No. 19 Somerton Victoria 3062.

These warranty conditions apply to Australia only. Purchases in other countries should refer to their local distributor for warranty conditions.

2. SAFETY INSTRUCTIONS



WARNING

To ensure safe operation

- Read and understand the Owner's Manual before operating the mower. Failure to do so could result in personal injury or equipment damage.
- Read instructions carefully, become familiar with controls and proper use of equipment.
- Never allow children or people unfamiliar with these instructions to use the lawn mower.
- Never mow while people, especially children, or pets are nearby.
- Keep in mind that the operator is responsible for accidents or hazards that occur to people or their property.
- While mowing, always wear substantial footwear and long trousers. Do not operate the equipment when barefoot or wearing open sandals.
- Thoroughly inspect the area where the equipment is to be used and remove all objects which may be thrown by the machine.
- Petrol is highly flammable:
 - Store fuel in containers specifically designed for this purpose
 - Refuel outdoors only and do not smoke while refuelling
 - Add fuel before starting the engine. Never remove the cap of the fuel tank or add petrol while the engine is running or when the engine is hot.
 - If petrol is spilled, do not attempt to start the engine but move the machine away from the area of spillage and avoid creating any source of ignition until the petrol vapours have dissipated.
- Before using, always visually inspect to see that the blade, blade bolt(s) and mower housing are not worn or damaged. Replace worn or damaged blade and bolt(s) in sets to preserve balance.
- Do not operate the engine in a confined space where dangerous carbon monoxide fumes can collect.
- Mow only in daylight or good artificial light.
- Avoid operating the equipment in wet grass, where feasible.
- Mowing in slopes:
 - Always be sure of your footing on slopes.
 - Mow across slopes, never up and down.
 - Walk, never run.
 - Exercise extreme caution when changing direction on slopes.
 - Do not mow excessively steep slopes (20 degrees).

2. SAFETY INSTRUCTIONS - continued

- Use extreme caution when reversing or pulling the lawn mower toward you.
- Stop the blades if the lawn mower has to be tilted for transporting, when crossing surfaces other than grass and when transporting the lawn mower to and from the area to be mowed.
- Never operate the lawn mower with defective guards or shields, or without guards devices (for example, discharge guard).
- Do not attempt to make cutting height adjustments while the engine is running.
- Do not change the engine governor setting or over-speed the engine.
- Disengage drive clutch before starting the engine.
- Start the engine carefully according to the instructions and with feet well away from the blades.
- Do not tilt the lawn mower when starting the engine.
- Do not start the engine when standing in front of the discharge opening.
- Do not put hands or feet near or under rotating parts. Keep clear of the discharge opening at all times.
- Never pick up or carry a lawn mower while the engine is running.
- Stop the engine and disconnect the spark plug cap:
 - Before clearing a blockage or unclogging the lawn mower.
 - Before checking, cleaning or working on the lawn mower.
 - After striking a foreign object. Inspect the lawn mower for damage and make repairs before restarting and operating the lawn mower.
 - If lawn mower starts to vibrate abnormally, check immediately.
- Stop the engine:
 - Whenever you leave the lawn mower.
 - Before refuelling the lawn mower.
- Reduce the throttle setting during engine shut down and turn the fuel valve off at the conclusion of mowing.
- Keep all nuts, bolts and screws tight to be sure the equipment is in safe working condition.
- Never store the equipment with petrol in the tank inside a building where fumes may reach an open flame or spark.
- Allow the engine to cool before storing in any enclosure.
- To reduce the fire hazard, keep the engine, muffler, battery compartment (if applicable) and petrol storage area free of grass, leaves or excessive grease.
- Replace worn or damaged parts for safety.
- If the fuel tank has to be drained, this should be done outdoors.
- Wear eye protection.

3. COMPONENT IDENTIFICATION

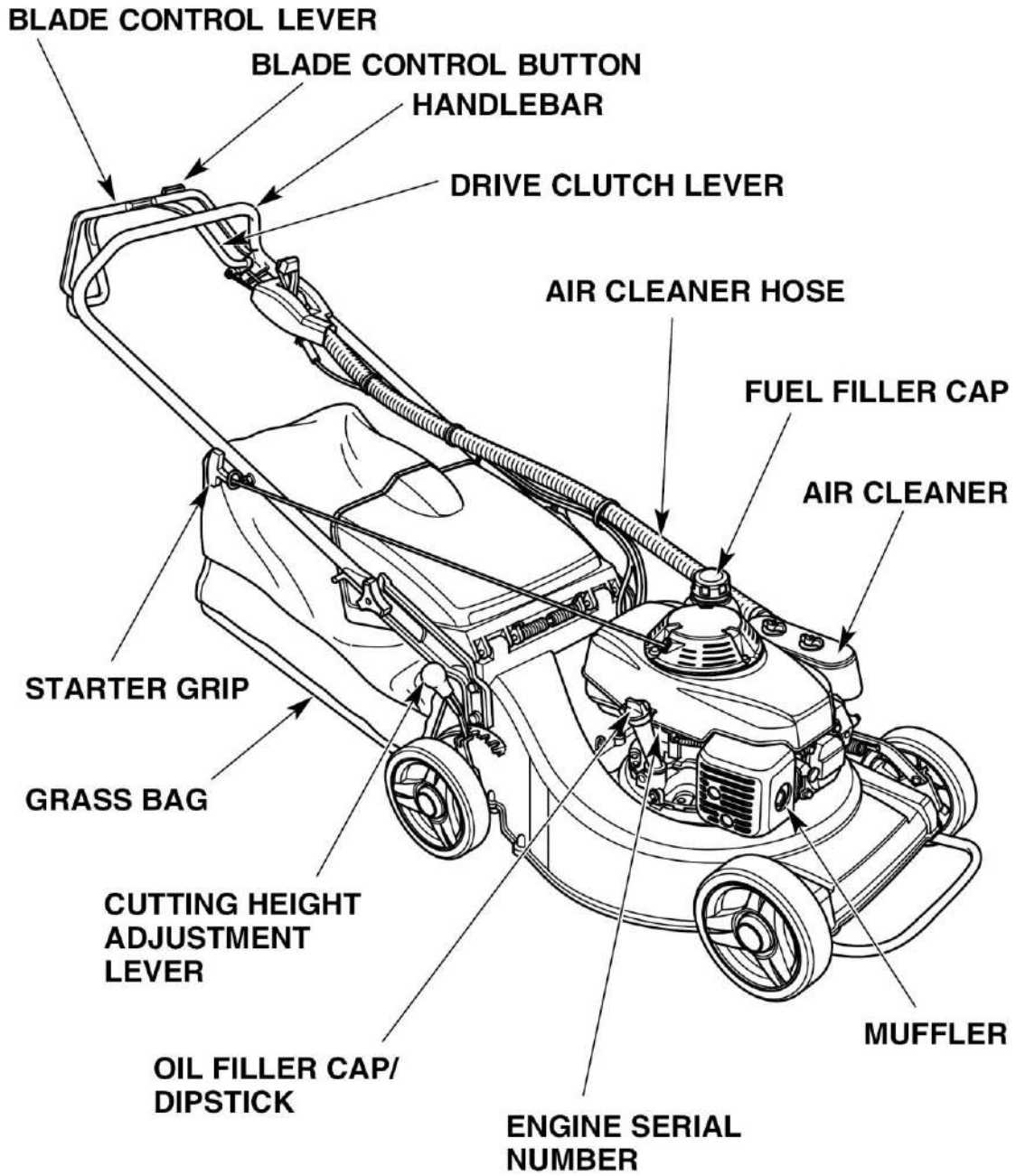

3. COMPONENT IDENTIFICATION - continues

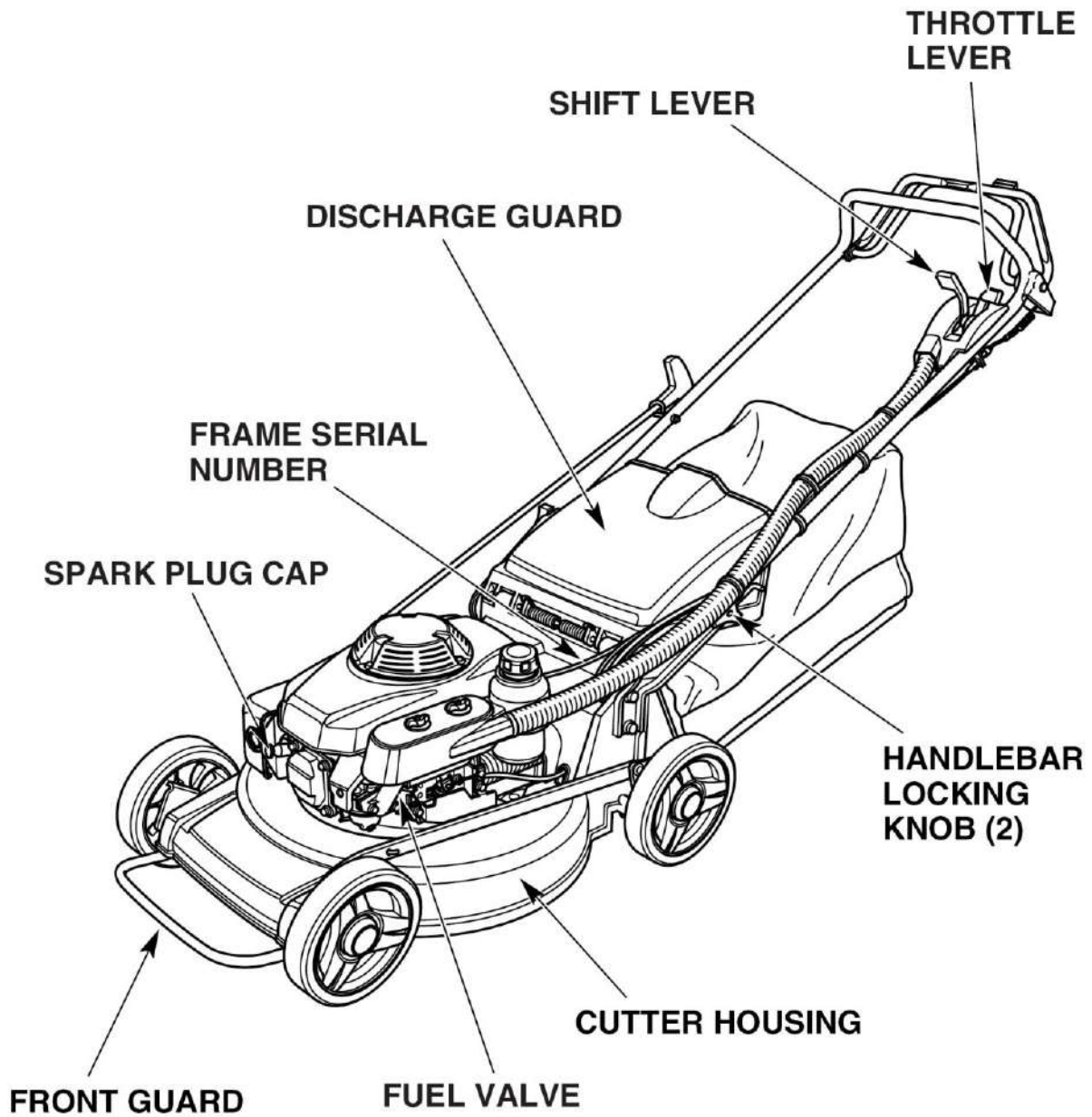

Record the frame and engine serial numbers and date of purchase in the space below. You will need these serial numbers when ordering parts and when making technical or warranty inquiries.

Frame Serial Number: _____
Engine Serial Number: _____
Date of Purchase: _____

4. CONTROLS

DESCRIPTION OF CONTROLS

Fuel Valve

The fuel valve opens and closes the fuel passage from the fuel tank to the carburetor. The fuel valve must be ON to start and operate the mower. The fuel valve should be kept OFF when the mower is not in use.

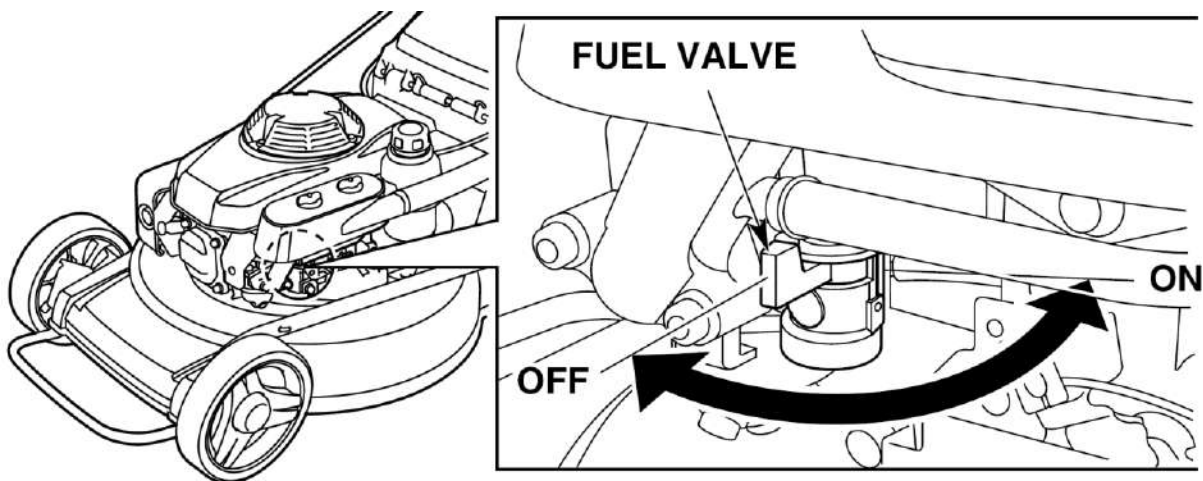

Throttle Lever

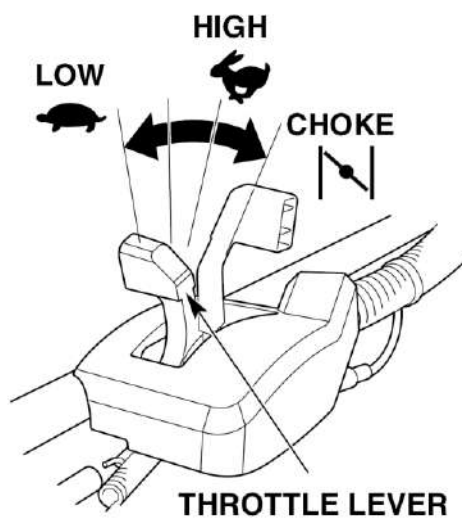

4. CONTROLS – continued

Blade Control Lever

This lever is connected to the Roto-Stop blade control system. The blades will not turn unless the blade control button is pushed in conjunction with the blade control lever being pushed forward.

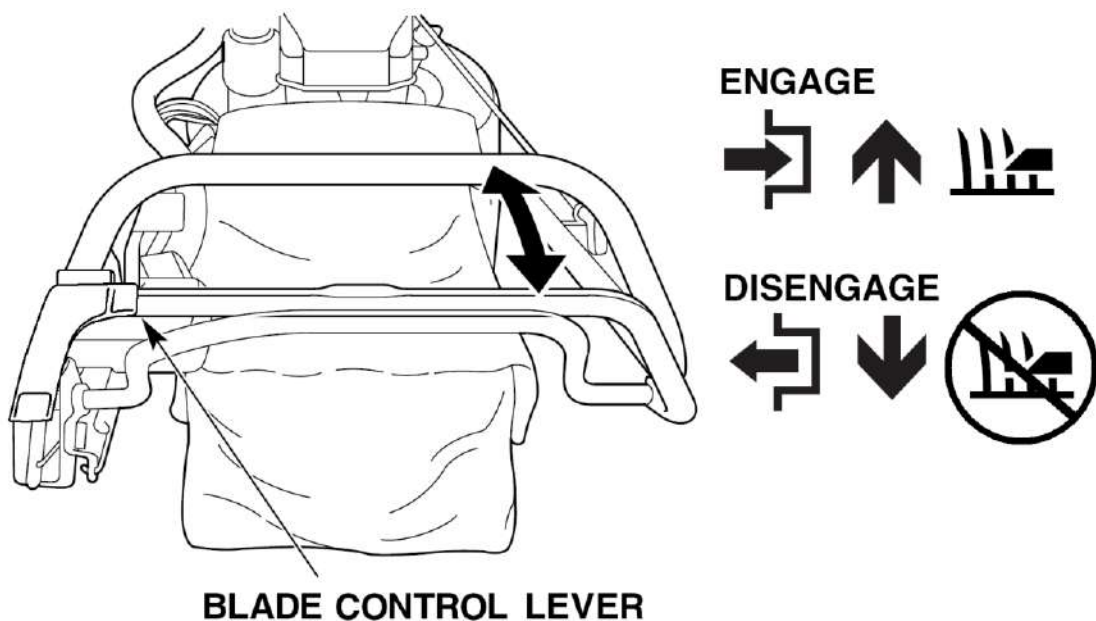

4. CONTROLS - continued

Drive Clutch Lever

The drive clutch lever engages (push forward) and disengages (release) the transmission that drives the rear wheels. The drive clutch lever should only be engaged after the engine has been started.

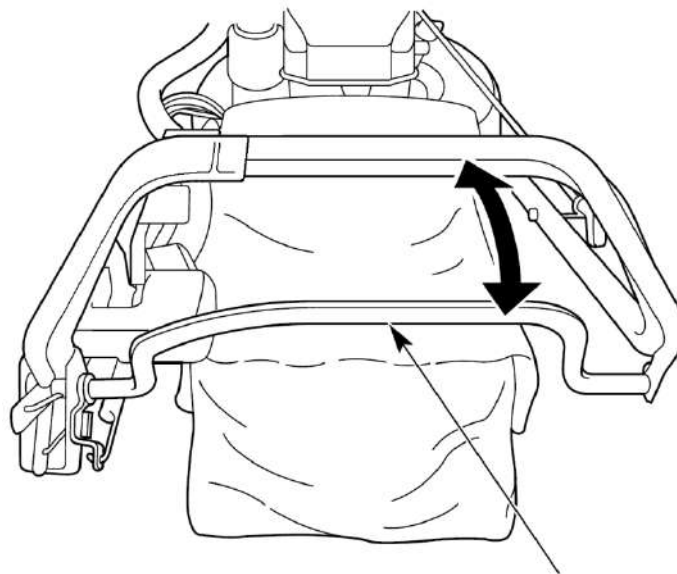

DRIVE CLUTCH LEVER

ENGAGE



DISENGAGE



4. CONTROLS - continued

Cutting Height Adjustment Lever

All wheels of the mower can be adjusted with one lever.

The cutting height figures are approximate. The actual height of cut grass will vary with lawn and soil conditions.

Move the adjuster forward to lower and back to raise the cutter housing.

Position	Approx. Height
①	76 mm
②	70 mm
③	64 mm
④	58 mm
⑤	51 mm
⑥	45 mm
⑦	39 mm
⑧	33 mm
⑨	28 mm
⑩	22 mm
⑪	16 mm

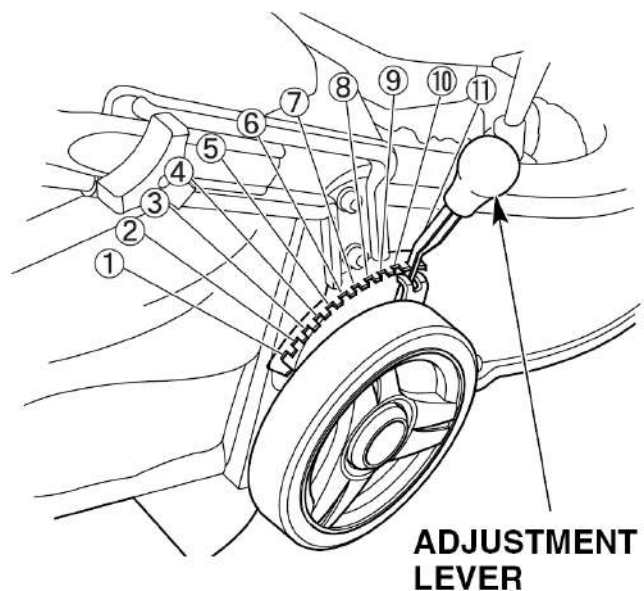

4. CONTROLS - continued

Shift Lever

The shift lever selects and controls the self-propelled drive speed.

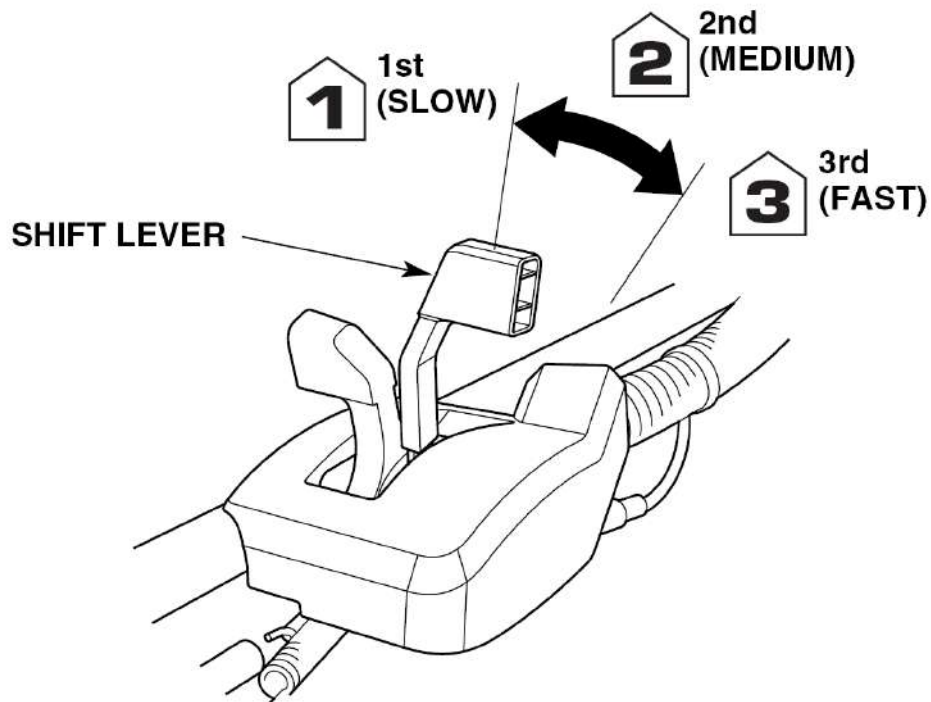

- 1** 1st (SLOW) For mowing thick grass or manoeuvring in small areas.
- 2** 2nd (MEDIUM) For intermediate self-propelled mowing speed.
- 3** 3rd (FAST) For maximum self-propelled transport speed.

4. CONTROLS - continued

Front Guard

Use the front guard when lifting the lawn mower, the front guard can also be utilised to tie down lawnmower for transportation (See page 36).

NOTICE

Do not step on the front guard.

Replace the front guard at an authorised Honda service dealer whenever it is deformed.

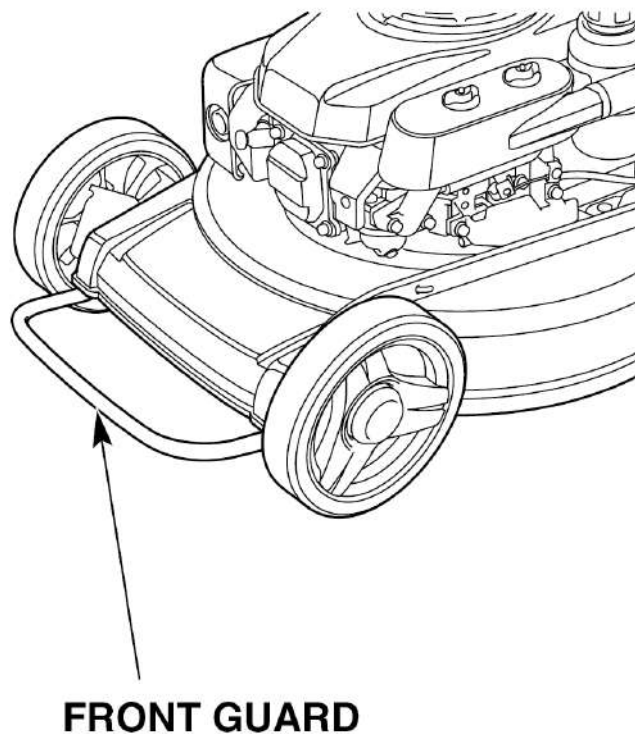

5. PRE-OPERATION CHECKS

ARE YOU READY TO MOW?

Be sure to wear protective clothing. Long pants and eye protection can lower your risk of injury from thrown objects. Wear footwear that protects your feet and won't let you slip if you mow on slopes or uneven ground.

CHECK YOUR LAWN

For your safety and for the safety of others, always inspect the area before mowing.

OBJECTS

Anything which can be picked up by the blades and thrown is a potential hazard to you and others. Look for things like stones, sticks, bones and wire. Remove them from the mowing area.

PEOPLE & PETS

People and animals near the mowing area can move into your path or into a position where they could be struck by thrown objects. Clear the area of people and pets, especially children. Their safety is your responsibility.

LAWN

Check the length and condition of the grass, so you will know what cutting height and mowing speed to use.

Avoid mowing wet grass. Not only will wet grass clog your cutter housing and collect in clumps on the lawn, it also gives poor traction, increasing your risk of losing your footing.

5. PRE-OPERATION CHECKS - continued

CHECK YOUR MOWER

Blades

Before each use, check the cutter blades for damage or excessive wear.

WARNING

To avoid severe personal injury, disconnect the spark plug cap to prevent accidental starting, and wear heavy gloves to protect your hands from the cutter blades.

1. Stop the engine and turn the fuel valve to the OFF position.
2. Disconnect the spark plug cap from the spark plug (see page 48).
3. Remove the grass bag (if installed).
4. Tilt the mower to the right, so the carburetor side is up. This will help to prevent fuel leakage and hard starting.

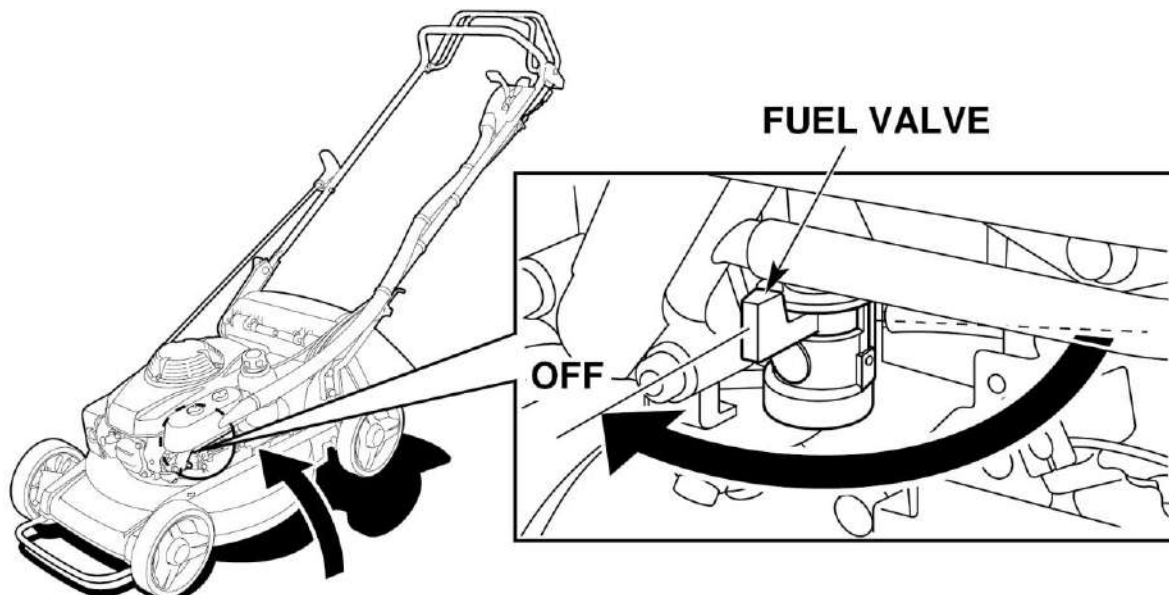

5. PRE-OPERATION CHECKS - continued

5. Inspect the blades for wear and damage.
6. Check that the blade setting bolts and the blade disc holder bolt are tight (see page 51).

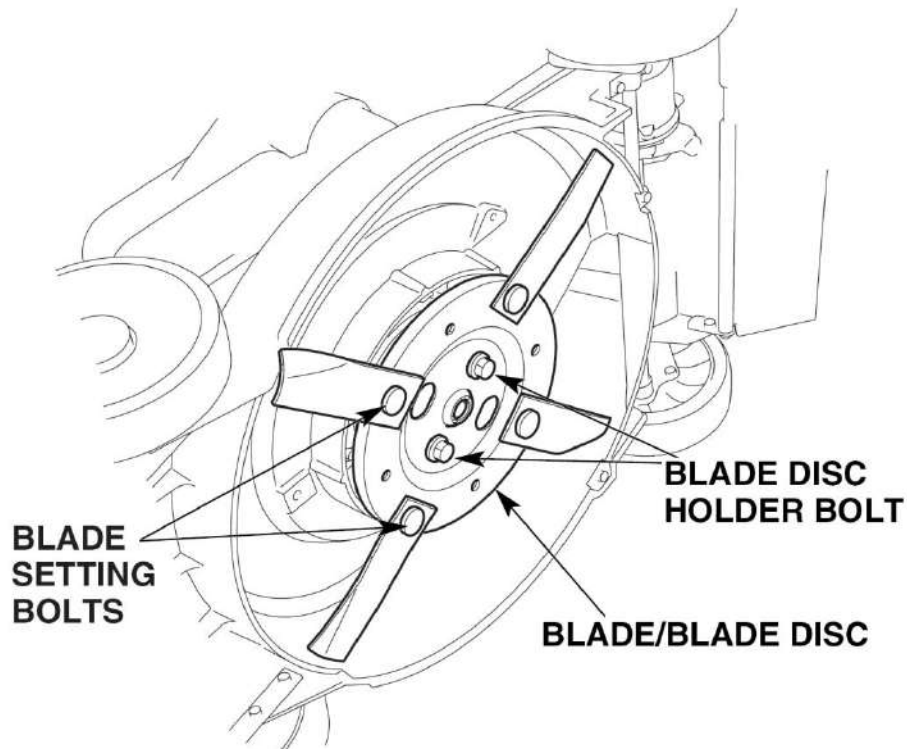

WARNING

Never operate the mower with a worn, damaged, split or dented blade. A piece of blade which breaks off and is thrown outwards can cause serious bodily injuries.

5. PRE-OPERATION CHECKS - continued

NOTICE

Blade wear is increased when the mower is used on sandy soils. Inspect the blades more often when the mower is used in these conditions.

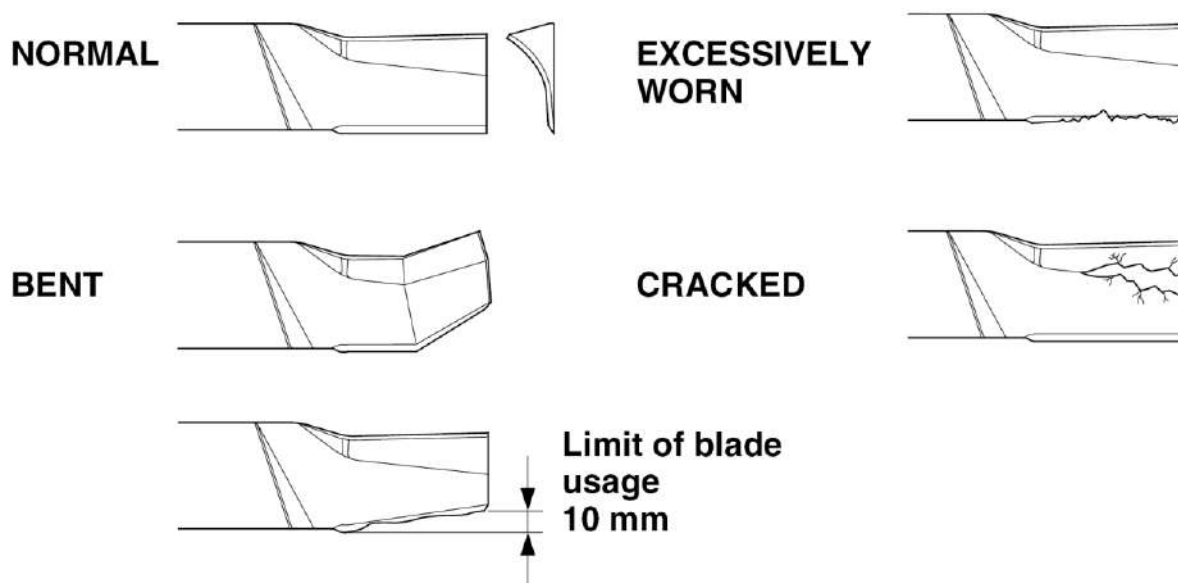

A dull blade can be sharpened, but a blade that is worn out, bent, cracked or otherwise damaged must be replaced. A worn or damaged blade can break, causing blade pieces to be thrown from the mower.

When a blade needs sharpening or replacement, take the lawn mower to an authorised Honda servicing dealer. If you have a torque wrench and the other correct tools, you can remove and install the blades yourself (see page 51).

5. PRE-OPERATION CHECKS - continued

Engine Oil Level

Check the engine oil level with the engine stopped and the mower on a level surface.

1. Clean the area around the oil filler cap.
2. Remove the oil filler cap, and wipe the dipstick clean.
3. Insert and remove the dipstick without screwing it into the filler neck. Check the oil level shown on the dipstick.
4. If the oil level is low, add the recommended oil (see page 46) to reach the upper limit mark on the dipstick. Do not overfill.
5. After checking the engine oil level, screw in the oil filler cap/dipstick securely.

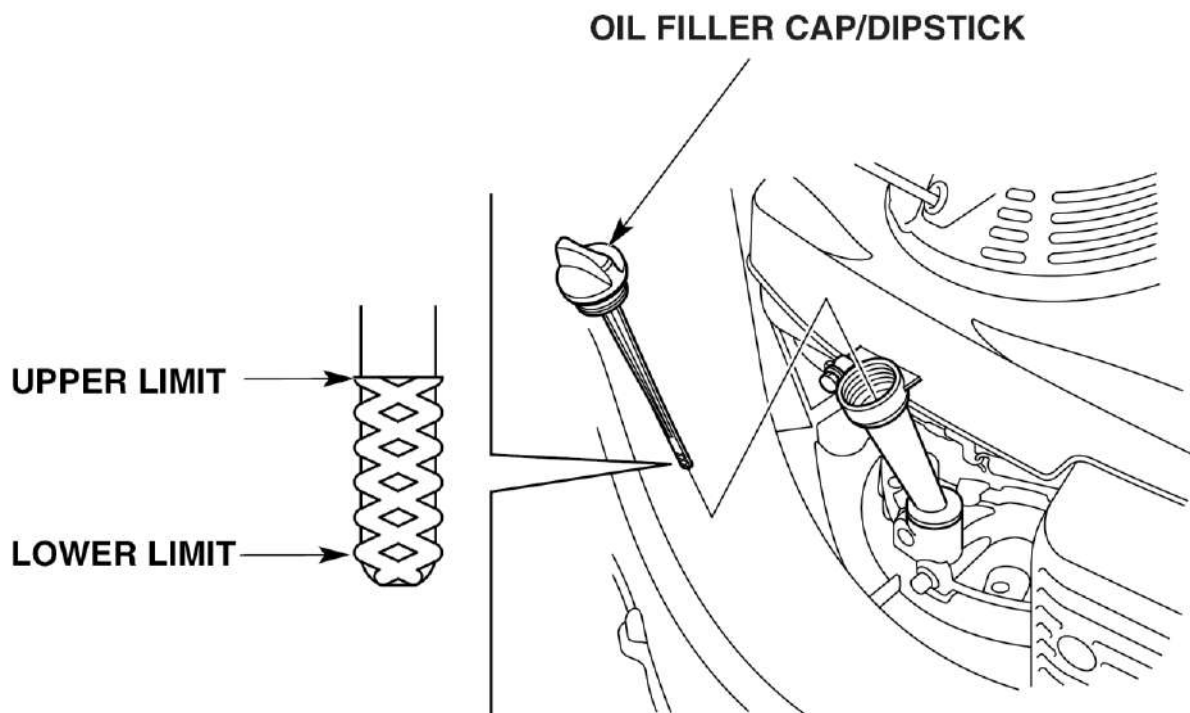

5. PRE-OPERATION CHECKS - continued

Fuel

Refuel in a well-ventilated area before starting the engine. If the engine has been running, allow it to cool. See page 50 for fuel recommendations.

Remove the fuel filler cap and check the fuel level. Refill the tank if the fuel level is low. Refuel carefully to avoid spilling fuel. Do not overfill; there should be no fuel over the limit mark. After refuelling, tighten the fuel filler cap securely.

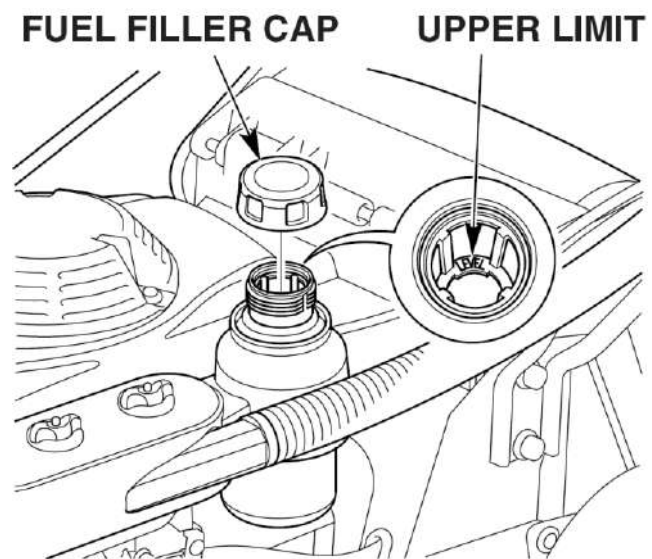

WARNING

Petrol is highly flammable and explosive.

You can be burned or seriously injured when handling fuel.

- **Stop the engine and keep heat, sparks and flame away.**
- **Handle fuel only outdoors.**
- **Wipe up spills immediately.**

Do not smoke while refuelling the mower. Never refuel the mower inside a building where petrol fumes may reach flames or sparks. Keep petrol away from appliances with pilot lights, barbecues, electric appliances, etc.

NOTICE

Fuel can damage paint and plastic. Be careful not to spill fuel when filling your fuel tank. Damage caused by spilled fuel is not covered under warranty.

5. PRE-OPERATION CHECKS - continued

Air Cleaner

Inspection

Make sure the air filters are clean and in good condition. A dirty air filter will restrict air flow to the carburetor, reducing engine performance. Refer to page 47 for air cleaner service.

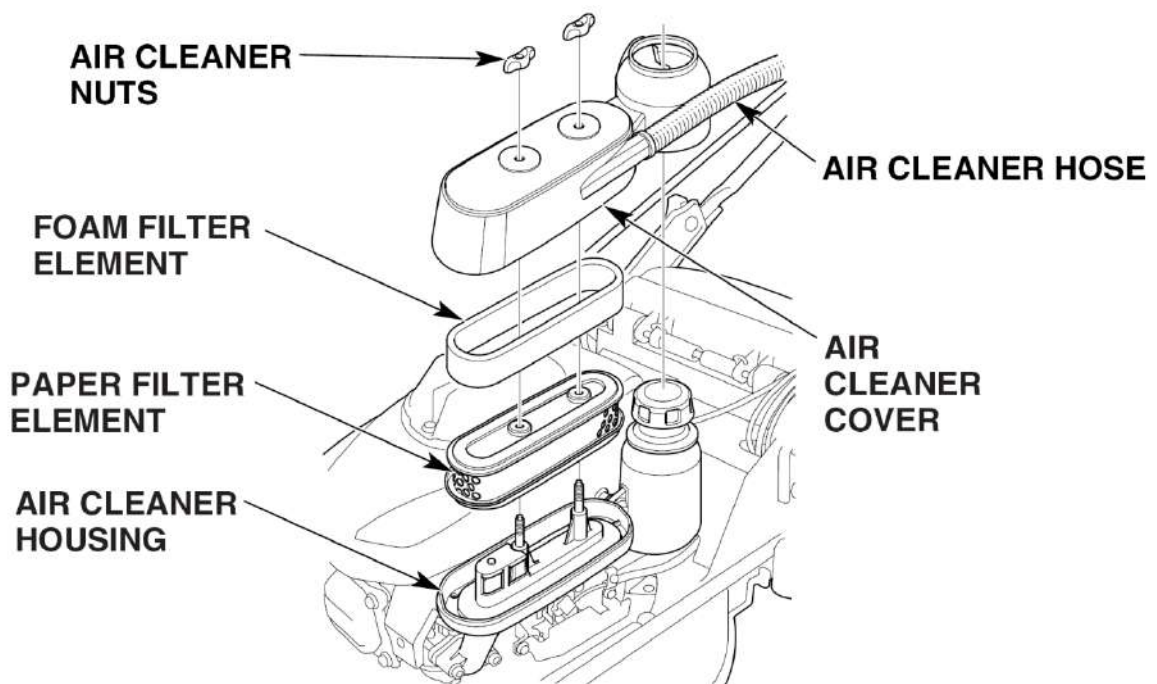

Grass Bag

A lawn mower works like a vacuum cleaner; it blows air through the bag, which traps the grass clippings. Always empty the grass bag before it becomes filled to the limit of its capacity. Bagging performance will diminish after the bag becomes about 90% filled. Also the bag is easier to empty when not packed full.

Inspection

Inspect the grass bag before use.

Check for holes, tears and excessive wear.

The grass bag will wear during normal use and will eventually require replacement (See page 56).

5. PRE-OPERATION CHECKS - continued

Installation

1. Raise the discharge guard and hook the grass bag frame onto the cutter housing as shown.
2. Release the discharge guard to secure the grass bag in place.

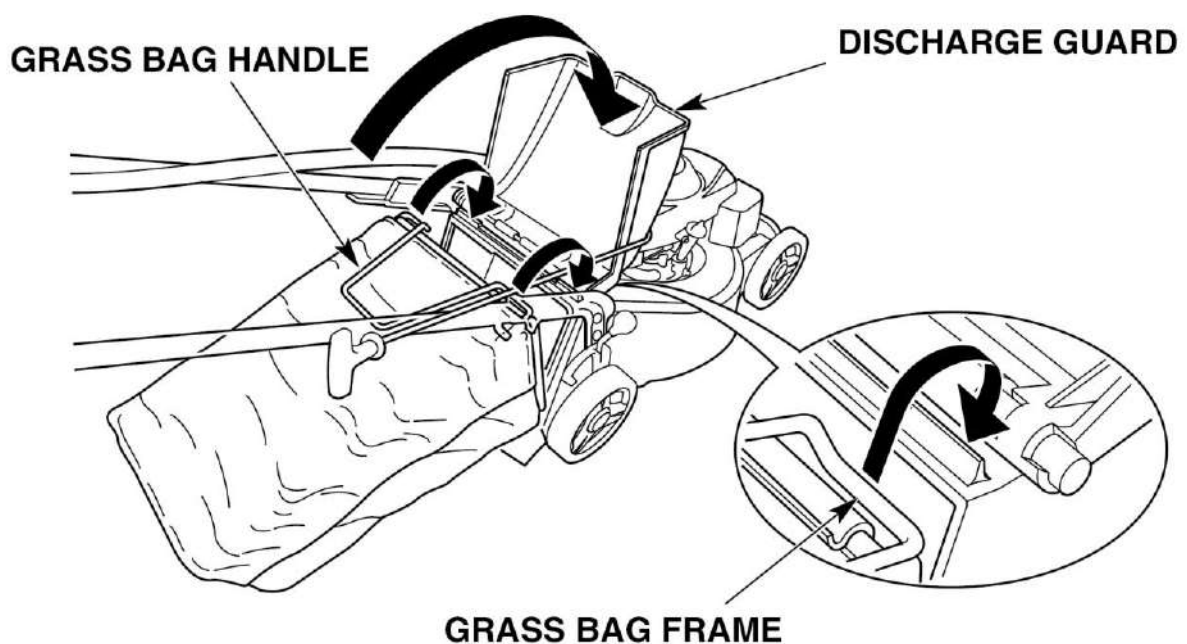

Removal

1. Raise the discharge guard, grasp the grass bag handle and remove the grass bag.
2. Release the discharge guard.
3. When the grass bag is clear of the discharge guard, you can lift the grass bag through the handlebars, or remove it from the rear of the mower below the handlebar.

5. PRE-OPERATION CHECKS - continued

Cutting Height

Check the cutter housing height settings. The lowest is approximately 16 mm and the highest setting is 76mm. To adjust cutting height, pull the adjustment lever toward the wheel, and move it into another notch.

If you are not sure what cutting height to select, start with a high setting and check the appearance of the lawn after mowing a small area. Then readjust cutting height if necessary.

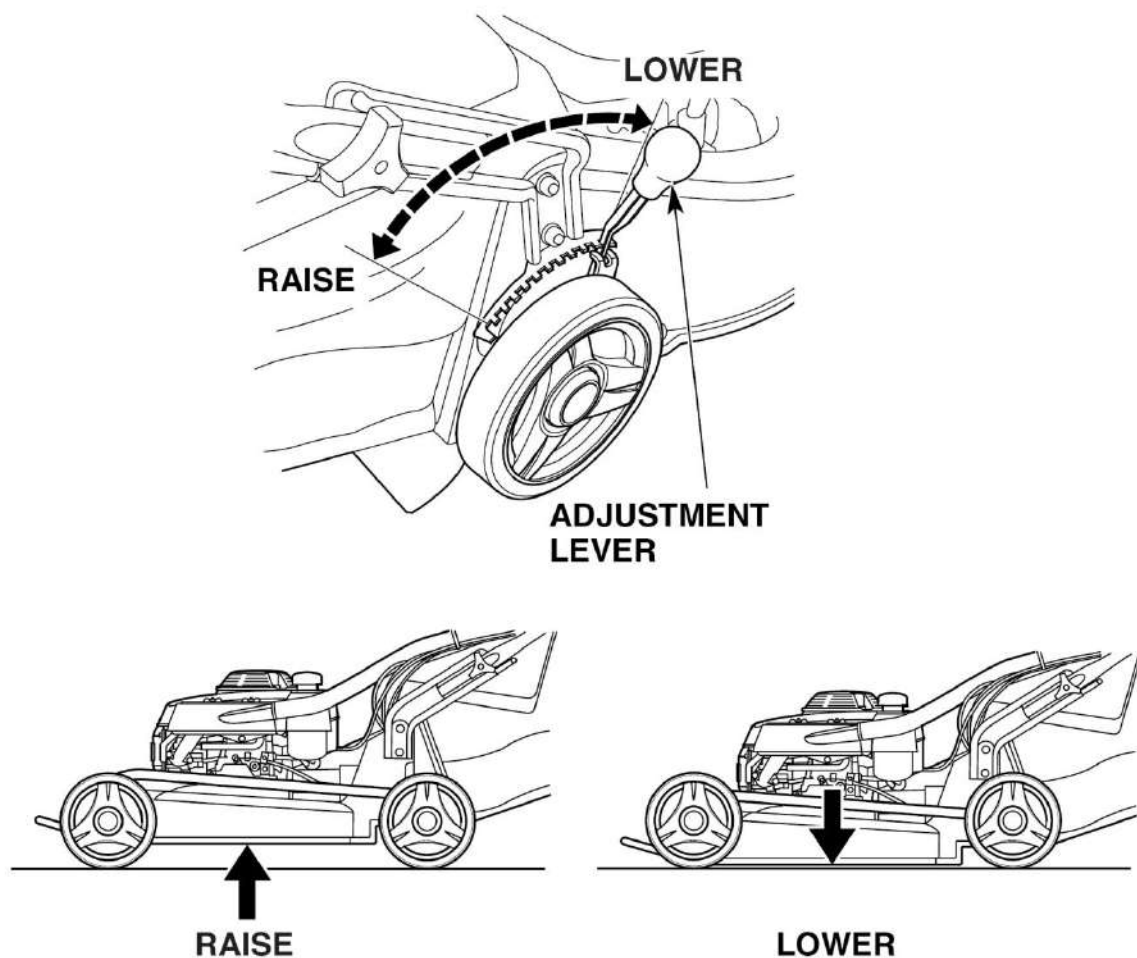

6. OPERATION

MOWING PRECAUTIONS

Before operating the mower for the first time, please review the SAFETY INSTRUCTIONS beginning on page 5 and SAFE MOWING PRACTICES on page 31.

Even if you have operated other mowers, take time to become familiar with how this mower works and practice in a safe area until you build up your skills.

For your safety, avoid starting or operating the engine in an enclosed area such as a garage. Your mower's exhaust contains poisonous carbon monoxide gas which can collect rapidly in an enclosed area and cause illness or death.

STARTING THE ENGINE

1. Turn the fuel valve to the ON position.

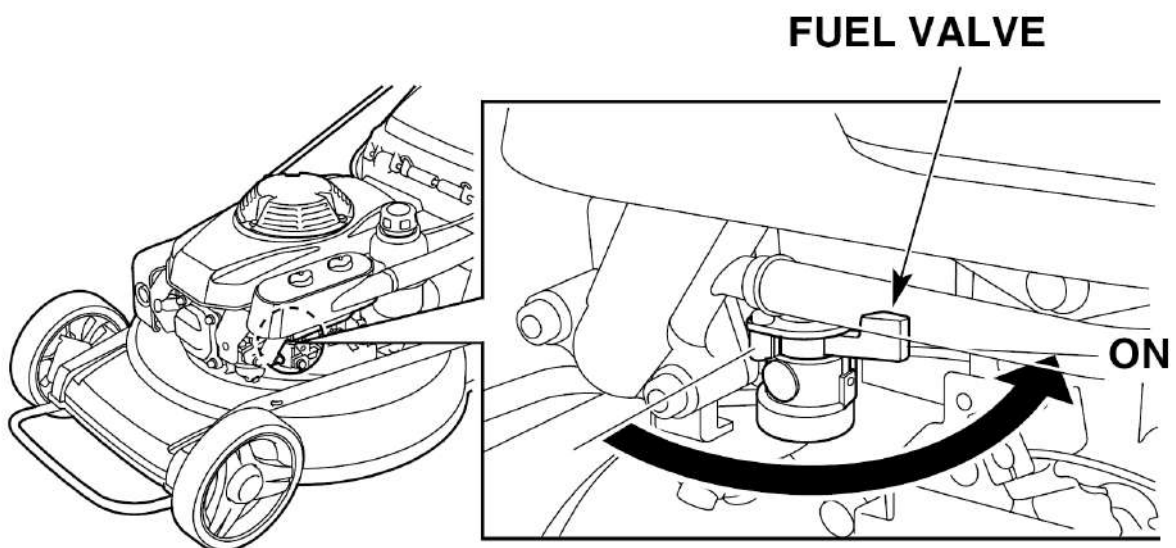

6. OPERATION - continued

2. Move the throttle lever to the proper starting position

COLD ENGINE:

Move the throttle lever to the CHOKE position.

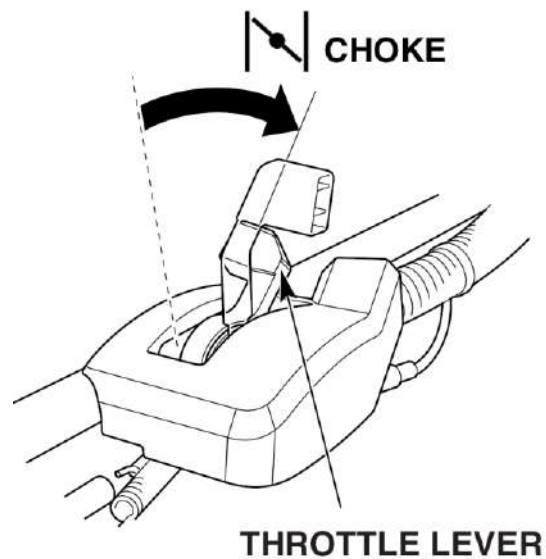

WARM ENGINE:

Move the throttle lever to the HIGH position.

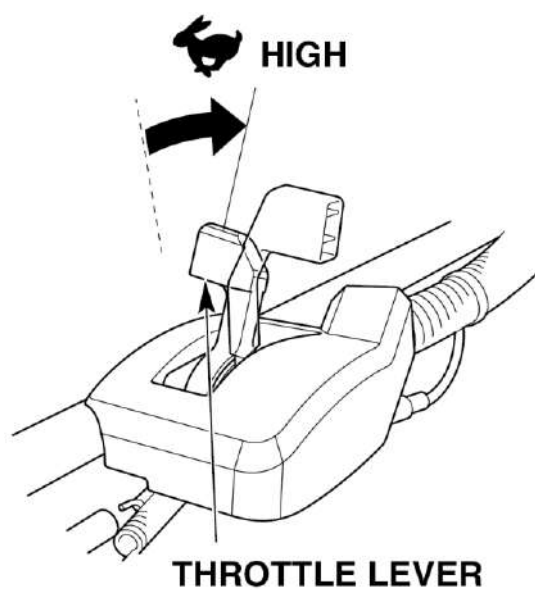

6. OPERATION - continued

3. Release the drive clutch lever. If the drive clutch lever is engaged, the mower will move forward when you operate the starter.
4. Pull the starter grip lightly until you feel resistance, then pull briskly in the direction of the arrow as shown below. Return the starter grip gently. Keep your hands and feet away from the cutter housing at all times when starting and running the engine.

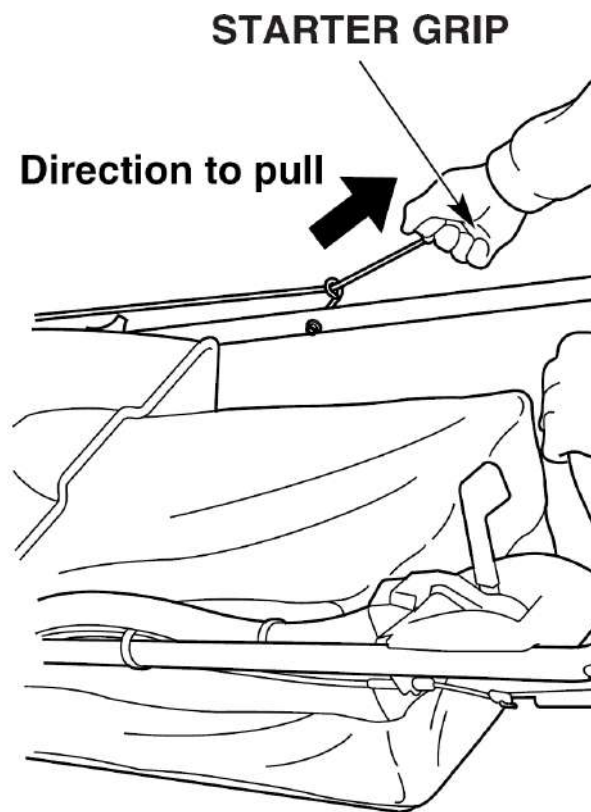

5. If the CHOKE position was used during starting, move the throttle lever away from the CHOKE position as soon as the engine warms up enough to run smoothly. Set the throttle lever at HIGH to mow or at LOW to idle.

6. OPERATION - continued

OPERATING THE CONTROLS FOR MOWING

Throttle Lever

For best cut quality, always mow with the throttle lever in the HIGH position. When the blades rotate at the preset fast speed, it creates a strong fan action that lifts and cuts grass more efficiently. Do not try to increase the preset engine speed, the blades could fracture and come apart.

When you need to leave the mower for any reason, always turn the engine OFF by moving the throttle lever to the STOP position.

Blade Control Lever

To start blade rotation, press the button on top of the blade control lever, then push the lever forward quickly and hold it against the handlebar. To prevent stalling, always put the throttle lever in the fast position before engaging the blade control lever.

Release the blade control lever to stop the blades.

Operate the blade control lever with a quick and complete motion, so the blade control is always either fully engaged or stopped. This will help to prevent stalling the engine, and will also extend the service life of the blade control mechanism.

Always release the blade control lever before starting the engine to prevent the blades from turning.

BLADE CONTROL LEVER

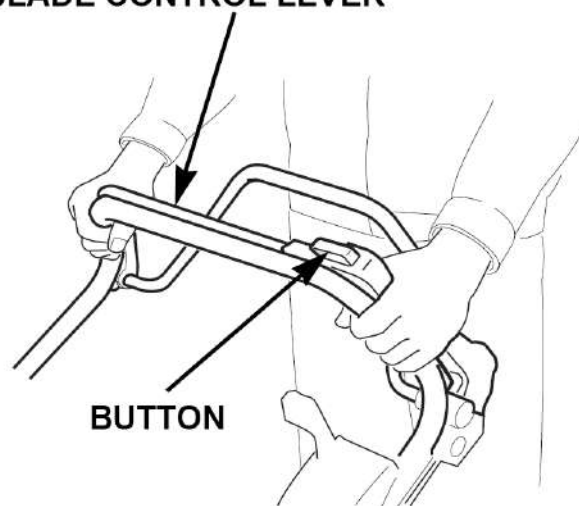

6. OPERATION - continued

Drive Clutch Lever

Push the drive clutch lever forward and hold it against the handlebar to propel the mower forward.

Release the drive clutch lever to stop the mower's forward movement.

Always release the drive clutch lever before starting the engine. If the drive clutch is engaged, the mower will move forward when you operate the starter.

Operate the drive clutch lever with a quick and complete motion, so the drive clutch is either fully engaged or released. Hold the drive clutch lever against the handlebar during self-propelled mowing. This will help to extend the service life of the clutch mechanism.

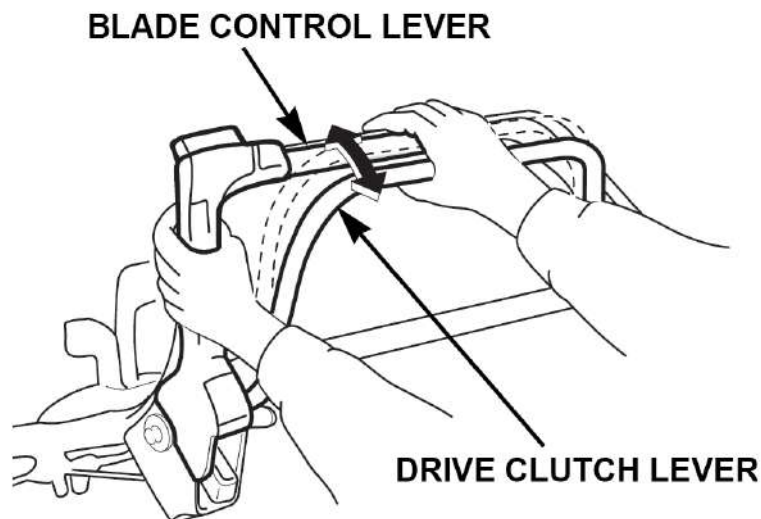

6. OPERATION - continued

Shift Lever

With the drive clutch released, move the shift lever to select 1st (slow), 2nd (medium) or 3rd (fast).

Do not use the throttle lever to adjust your forward speed. Forward speed should be adjusted with the shift lever, not the throttle lever. The throttle lever must remain in the "HIGH" position for good mowing performance. Otherwise, cut quality suffers.

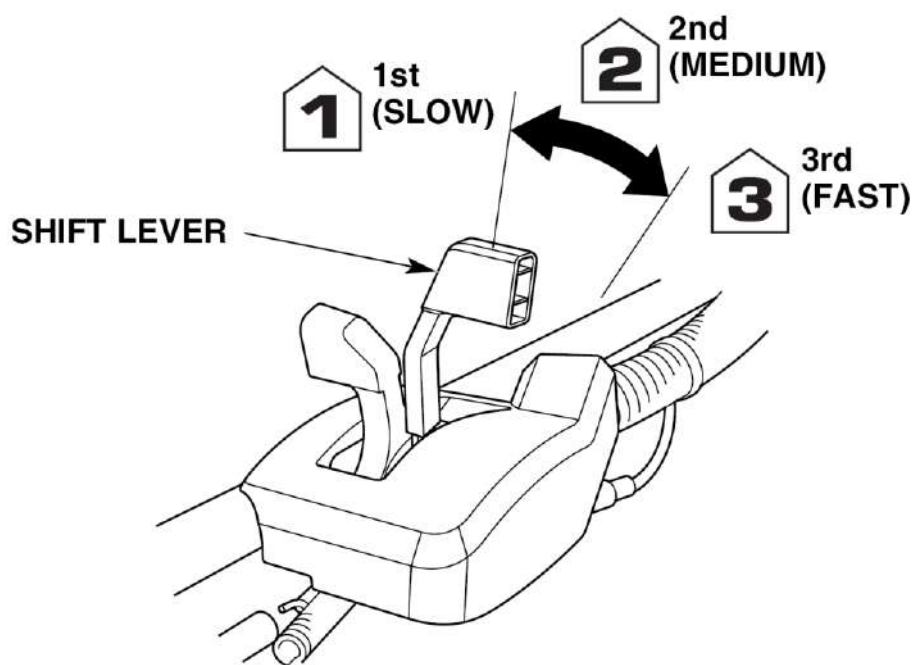

The speed must only be changed with the mower stationary, release the clutch lever before changing gears.

For maximum mowing performance, use 1st and 2nd gears for mowing and 3rd gear for transporting.

To avoid incomplete gear engagement, be sure the shift lever is centered in one of the three detent positions.

6. OPERATION - continued

STOPPING THE ENGINE

1. Release the drive clutch lever and the blade control lever.

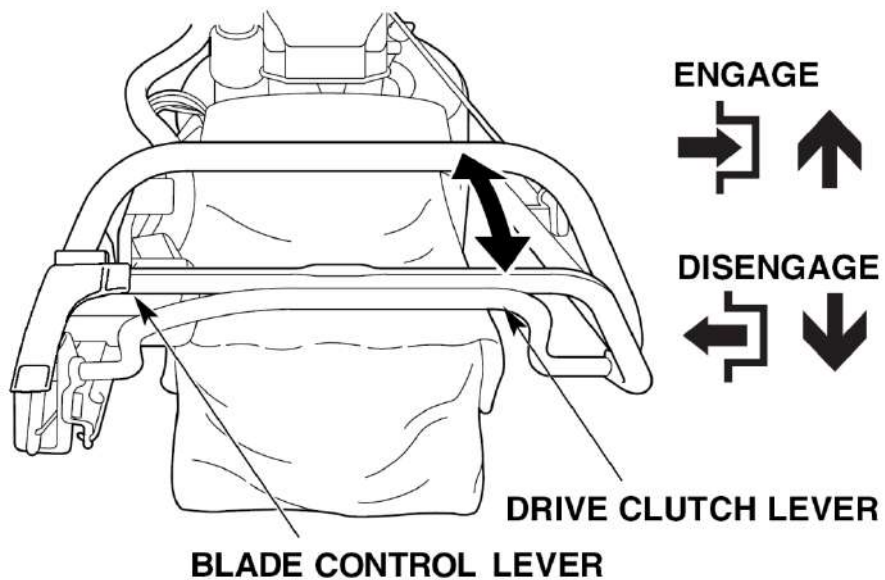

2. Move the throttle lever to the STOP position.

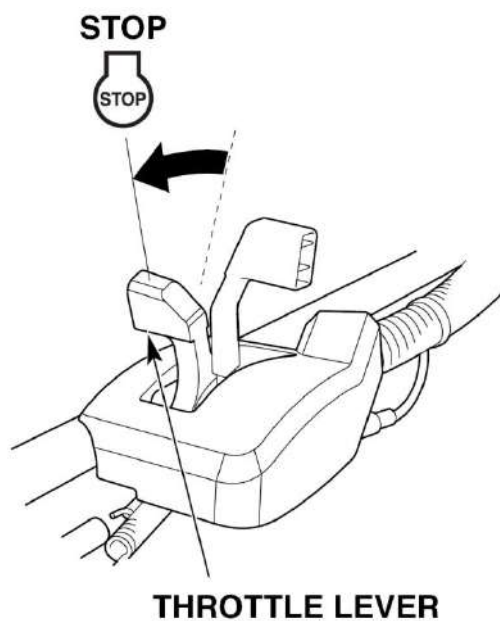

3. When the mower is not in use, turn the fuel valve to the OFF position (Page 9).

6. OPERATION - continued

SAFE MOWING PRACTICES

For your safety, keep all four wheels on the ground and be careful to avoid losing your footing and your control of the mower. Keep a firm grip on the handlebar and walk, never run with the mower. Be very careful when mowing uneven or rough ground.

If stuck, do not kick or shove the mower with your foot. Use the handlebar to control mower.

WARNING

The blades are sharp and spin at high speed.

A spinning blade can cut you severely and can amputate fingers and toes.

- **Wear protective footwear.**
- **Keep your hands and feet away from the cutter housing while the engine is running.**
- **Stop the engine before performing any adjustment, inspection or maintenance.**

Slopes

Mow across slopes, not up and down. Avoid steep slopes (more than 20°), and be careful when changing direction. Mowing on a slope when the grass is damp or wet could cause you to slip, fall and lose control of the mower.

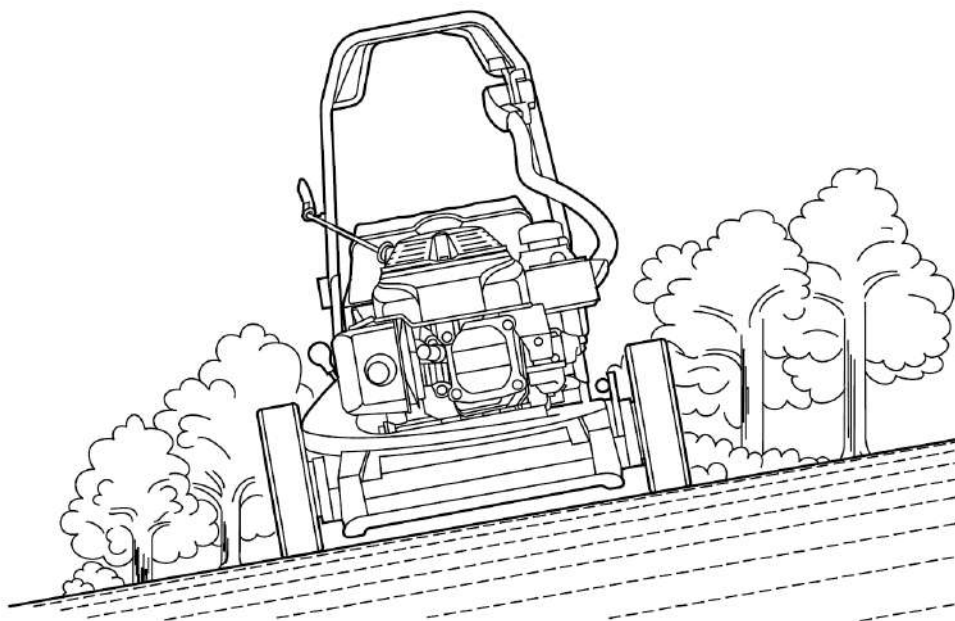

MAXIMUM SLOPE 20°

6. OPERATION - continued

Obstacles

Use the side of the mower to cut close to large obstacles, such as fences or walls.

Release the drive clutch lever to disengage the drive when mowing around trees and other obstacles. Push the mower around obstacles for better directional control. Be careful when mowing over obstacles embedded in the lawn, such as sprinkler heads, paving, edging, etc. Avoid anything that sticks up above the surface of the lawn.

If a blade hits something, or if the mower starts to vibrate, stop the engine immediately, disconnect the spark plug cap and check for damage (see page 16). Striking objects may damage the blades, bend the crankshaft, and/or break the cutter housing or other components. Vibration usually indicates damage to the mower or debris caught in the blades.

WARNING

A worn, cracked, or damaged blade can break, and pieces of the damaged blade can become dangerous projectiles.

Thrown objects can cause serious injury.

Inspect the blades regularly, and do not operate the mower with a worn or damaged blade.

The Warranty does not cover parts damaged by accident or collision.

Gravel and Loose Objects

Gravel, loose stones and landscaping material can be picked up by the mower and thrown many feet with enough force to cause serious personal injury and/or property damage. The best way to prevent potential injury from thrown objects is to release the blade control lever to stop the blades before reaching areas with gravel, loose stones or landscaping material.

6. OPERATION - continued

MOWING TIPS

Cutting Height

Consult a local nursery or lawn and garden centre for cutting height recommendations and advice about specific types of grasses and growing conditions in your area.

If you look closely, you'll see that most grass has stems and leaves. If you cut off the leaves, you'll scalp the lawn. Let the grass recover between mowing. Your mower will work better and your lawn will look better.

If your grass gets too tall, cut it once at the highest cutting height setting, then mow again in 2 or 3 days. Don't take off more than one third of total grass height in any one mowing, or brown patches may develop.

Cutting height adjustment is explained on page 23

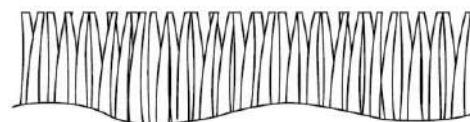
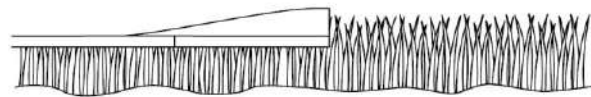

LONG ENOUGH



TOO SHORT

Cutting Width

For an even lawn finish, overlap each mowing swath by approximate 10cm. If the grass is very tall or thick, use more overlap and a narrower mowing swath.

Blade Speed

The blades must spin very fast to cut properly. Always use the HIGH throttle setting and keep the engine running at maximum rpm. If the engine speed drops, it could mean the engine is being overloaded by the blades trying to cut too much grass. Mow a narrower swath, move the mower slower, or raise the cutting height.

6. OPERATION - continued

Blade Sharpness

A sharp blade cuts cleanly. A dull blade tears the grass, leaving shredded ends that turn brown. When your blades don't cut cleanly anymore, have them sharpened or replaced.

Dry Grass

If the ground is too dry, mowing will stir up a lot of dust. Besides being unpleasant to work in, too much dust will clog the air filter. If dust is a problem, water your lawn the day before mowing. Mow when the grass is dry to your touch, but the soil is still moist.

Wet Grass

Wet grass is slippery and can make you lose your footing. Also, wet grass clippings will clog the cutter housing and collect in clumps on the lawn. Always wait for wet grass to dry before mowing.

Fallen Leaves

When equipped with the grass bag, your mower can be used to pick up fallen leaves for disposal. If using the mower to bag large amounts of fallen leaves, and not for mowing, set the cutting height adjustment lever at highest setting.

If you want to mulch fallen leaves into your lawn, don't let the leaf cover get too deep before you begin. For best results, start mulching while grass still shows through the leaf cover. In places where fallen leaves completely cover the grass remove the leaves by raking, or install a grass bag, so your mower can pick them up for disposal.

Clogged Cutter Housing

Before clearing a clogged cutter housing, stop the engine and turn the fuel valve to the OFF position. With the spark plug cap disconnected, tilt the mower so the carburetor side is up.

Clear a clogged deck with a stick, not by your hands.

6. OPERATION - continued

Mowing Patterns

Your Honda mower will work most efficiently if you use the following mowing patterns as much as possible. Cutter housing, equipment design and the direction in which the blades rotate, cause these mowing patterns to give the best results.

Bagging

Use a clockwise mowing pattern. This will give the best bagging performance, leaving the least amount of clippings on the lawn.

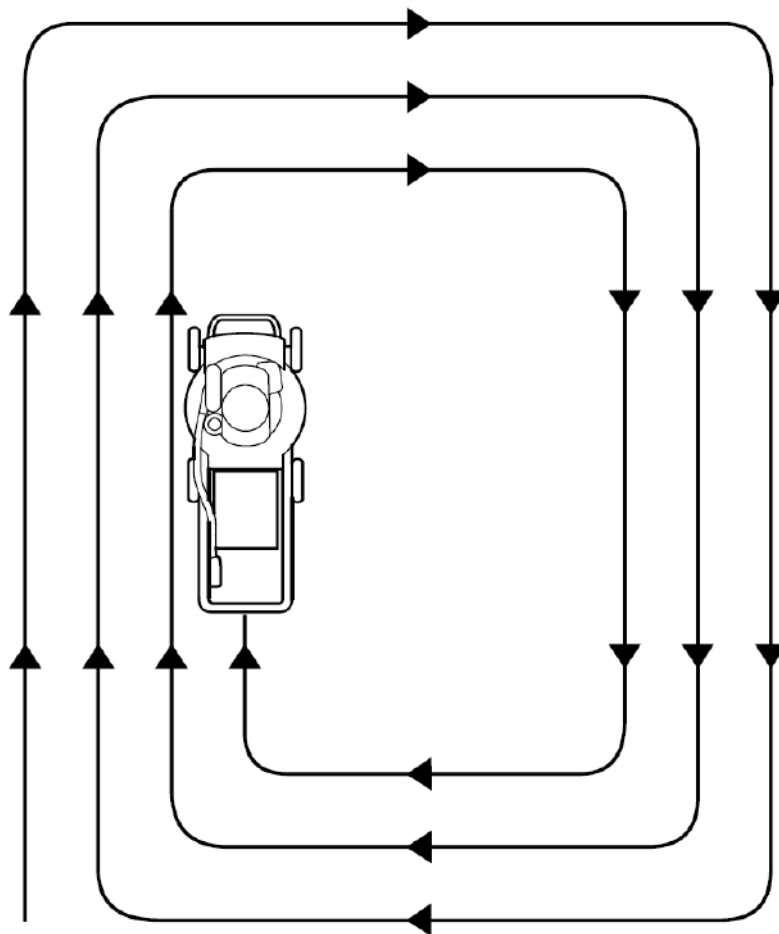

7. TRANSPORTING/STORAGE

BEFORE LOADING

If the engine has been running, allow it to cool for at least 15 minutes before loading the mower onto the transport vehicle. A hot engine and exhaust system can burn you and can ignite some materials.

Turn the fuel valve to the OFF position. This will prevent carburetor flooding and reduce the possibility of fuel leakage.

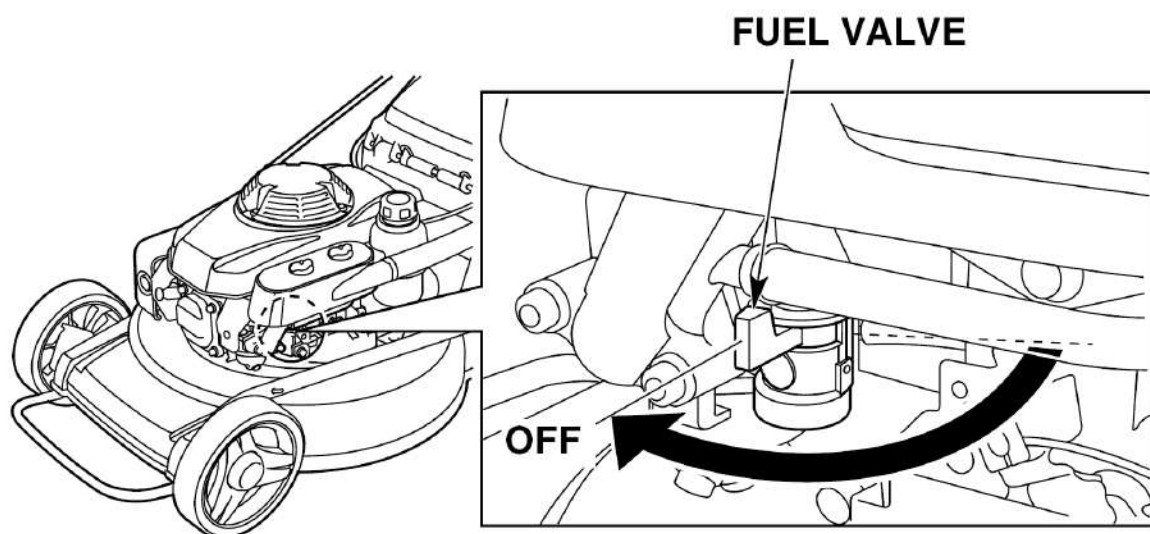

If equipped, remove the grass bag.

LOADING AND UNLOADING

If a suitable loading ramp is not available, two people should lift the mower on and off the transport vehicle while holding the mower level.

Position the mower so all four wheels are on the bed of the transport vehicle. Tie the mower down with rope or straps and block the wheels. Keep the tie-down rope or straps away from the controls, adjustment levers, cables and the carburetor.

The handlebar can be folded so the mower will take up less space (see page 40).

7. TRANSPORTING/STORAGE - continued

STORAGE PREPARATION

Proper storage preparation is essential for keeping your lawn mower trouble-free and looking good. The following steps will help to keep rust and corrosion from impairing your lawn mowers function and appearance and will make the engine easier to start when you use the lawn mower again.

Cleaning

1. Wash the lawn mower, including the underside of the cutter housing.

Engine

Wash the engine by hand and be careful to prevent water from entering the air cleaner and/or muffler.

NOTICE

- Using the garden hose or pressure washing equipment can force water into the air cleaner. Water in the air cleaner will soak the filters and can enter the carburetor or engine, causing damage.
- Water on a hot engine can cause damage. If the engine has been running, allow it to cool for at least 30 minutes before washing.

Cutter Housing

If using a garden hose or pressure washing equipment to clean the cutter housing, be careful to avoid getting water into controls and cables or anywhere near the engine air cleaner or muffler opening.

Before washing the underside of the cutter housing, be sure the fuel valve is in the OFF position. Disconnect the spark plug cap. Rest the mower on its right side, so the carburetor side is up. This will help to prevent fuel leakage and hard starting due to carburetor flooding. Wear heavy gloves to protect your hands from the blades.

2. After washing the lawn mower, wipe dry all accessible surfaces.
3. With the mower in an upright position, start the engine outdoors and let it run until it reaches normal operating temperature to evaporate any water remaining on the engine.
4. Stop the engine and allow it to cool.
5. After the lawn mower is clean and dry, touch up any damaged paint and coat other areas that may rust with a light film of oil. Lubricate the control cable cores with a silicone spray lubricant.

7. TRANSPORTING/STORAGE - continued

Fuel

Petrol will oxidize and deteriorate overtime when stored. Old petrol will cause hard starting and it leaves gum deposits that clog the fuel system. If the petrol in your mower deteriorates during storage, you may need to have the carburetor and other fuel system components serviced or replaced.

The length of time that petrol can be left in your fuel tank and carburetor without causing functional problems will vary with such factors as petrol blend, your storage temperatures and whether the fuel tank is partially or completely filled. The air in a partially filled fuel tank promotes fuel deterioration. Very warm storage temperatures accelerate fuel deterioration. Fuel deterioration problems may occur within 30 days or even less if the petrol was not fresh when you filled the fuel tank.

The Warranty does not cover fuel system damage or engine performance problems resulting from neglected storage preparation.

You can avoid fuel deterioration problems by draining the fuel tank and carburetor.

NOTICE

Petrol spoils very quickly depending on factors such as light exposure, temperature and time.

In worst cases, petrol can be contaminated within 30 days.

Using contaminated petrol can seriously damage the engine (carburetor clogged, sticking valves).

Such damage due to spoiled fuel is not warrantable.

To avoid this please strictly follow these recommendation:

- Only use specified petrol (see page 50).
- Use fresh and clean petrol.
- To slow deterioration, keep petrol in a certified fuel container.
- If long storage (more than 30 days) is foreseen, drain fuel tank and carburetor (see page 39).

7. TRANSPORTING/STORAGE - continued

Draining the Fuel Tank and Carburetor

1. Empty the fuel tank into an approved petrol container.
2. Remove the carburetor drain bolt with a 10mm wrench and drain the carburetor bowl fuel into an approved container.

WARNING

Petrol is highly flammable and explosive.

You can be burned or seriously injured when handling fuel.

- **Stop the engine and keep heat, sparks and flame away.**
- **Handle fuel only outdoors.**
- **Wipe up spills immediately.**

3. Turn the fuel valve to the ON position (see page 24). This will allow fuel in the fuel tank to drain through the carburetor bowl. After the fuel is completely drained, reinstall the sealing washer and the drain bolt.

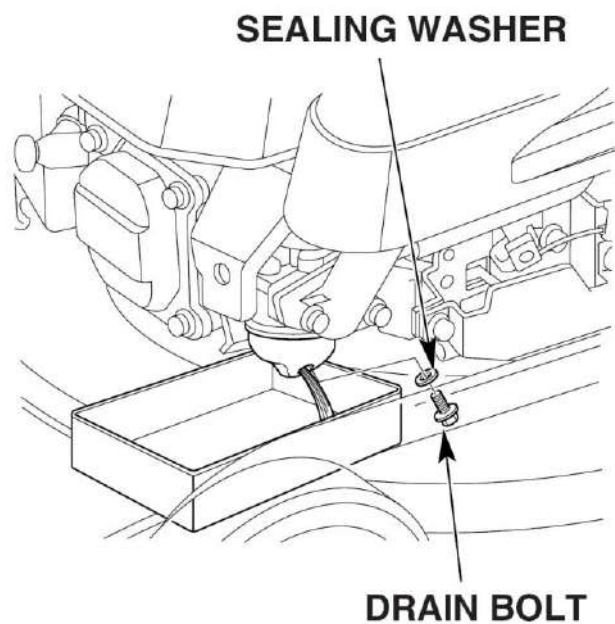

Engine Oil

Change the engine oil (see page 45).

Engine Cylinder

1. Remove the spark plug (see pages 48).
2. Pour 5-10cc (One Teaspoon) of clean engine oil into the cylinder.
3. Pull the starter grip several times to distribute the oil in the cylinder.
Reinstall the spark plug.
4. Pull the starter grip slowly until resistance is felt, then return the starter grip gently. This closes the valves so moisture cannot enter.

7. TRANSPORTING/STORAGE - continued

Handlebar Folding

1. Remove the grass bag (if installed).
2. Loosen or remove the two handlebar locking knobs.
3. Pull the handlebar struts to release them from the locating grooves, then swing the handlebar forward with the drive clutch lever held by your hand. Don't allow the cables and air cleaner hose to be bent or pinched.
4. Loosely install the two handlebar locking knobs.

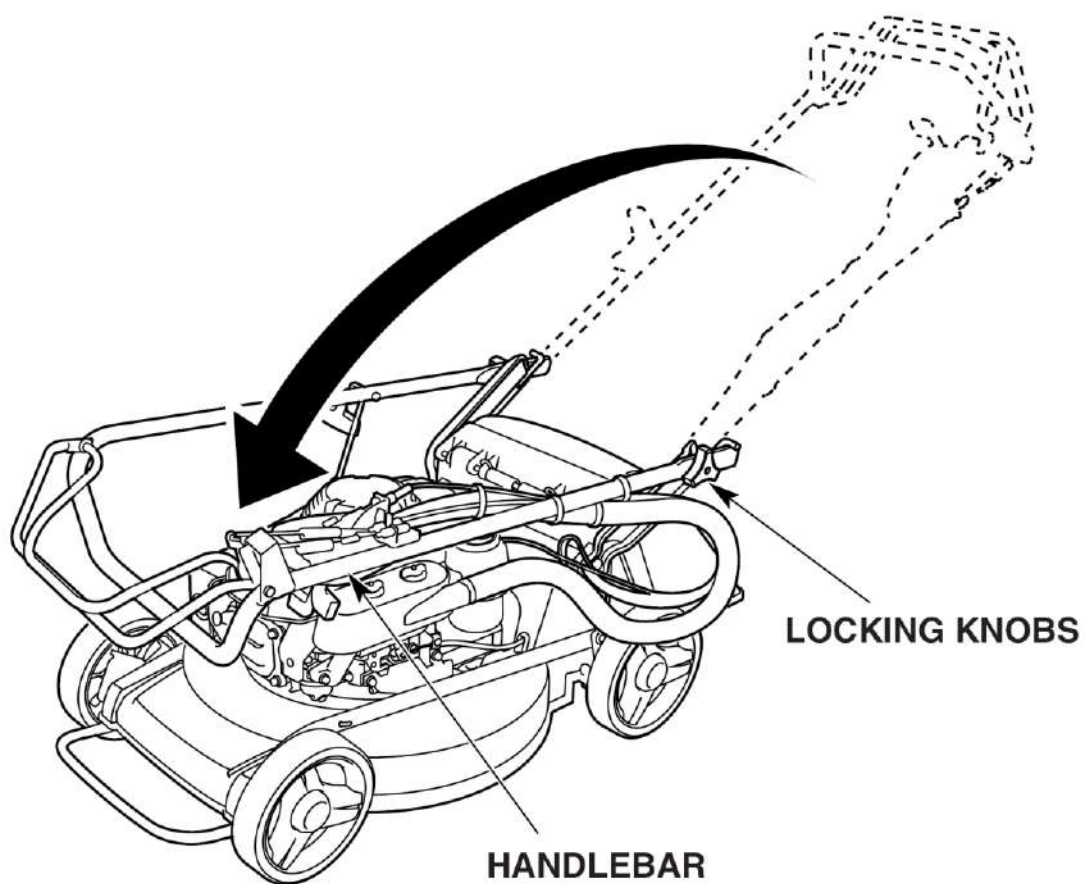

Handlebar Setting

Squeeze the drive clutch lever and raise the handlebar in place in the reverse order of handlebar folding, taking care that the cable and air cleaner hose are not bent or pinched.

7. TRANSPORTING/STORAGE - continued

STORAGE PRECAUTIONS

If your mower will be stored with petrol in the fuel tank and carburetor, it is important to reduce the hazard of petrol vapour ignition. Select a well ventilated storage area away from any appliance that operates with a flame, such as a furnace or water heater. Also avoid any area with a spark-producing electric motor, or where power tools are operated.

If possible, avoid storage areas with high humidity, humidity promotes rust and corrosion.

Unless all fuel has been drained from the fuel tank, turn the fuel valve to the OFF position to reduce the possibility of fuel leakage.

Place the mower with its wheels on a level surface. Tilting can cause fuel or oil leakage.

The handlebar can be folded for compact storage (see page 40).

With the engine and exhaust system cool, cover the mower to keep out dust. A hot engine and exhaust system can ignite or melt some materials. Do not use plastic sheet as a dust cover. A nonporous cover will trap moisture around the mower, promoting rust and corrosion.

If the cylinder was coated with oil during the storage preparation, the engine will smoke briefly at start-up. This is normal.

8. MAINTENANCE

THE IMPORTANCE OF MAINTENANCE

Good maintenance is essential for safe, economical and trouble-free operation. It will also help reduce air pollution.

WARNING

To avoid the mower starting accidentally, pull off the spark plug cap before carrying out maintenance work.

Improper maintenance or failure to correct a problem before operation can cause a malfunction in which you can be seriously hurt or killed.

Always follow the inspection and maintenance recommendations and schedules in this owner's manual.

To help you properly care for your mower, the following pages include a maintenance schedule, routine inspection procedures and simple maintenance procedures using basic hand tools.

Other service tasks that are more difficult or require special tools, are best handled by professionals and are normally performed by a Honda technician or other qualified mechanic. The maintenance schedule applies to normal operating conditions. If you operate your mower under severe conditions, such as sustained high-load conditions, consult your servicing dealer for recommendations applicable to your individual needs and use.

8. MAINTENANCE - continued

MAINTENANCE SAFETY

Some of the most important safety precautions follow. However, we cannot warn you of every conceivable hazard that can arise in performing maintenance. Only you can decide whether or not you should perform a given task.



Failure to properly follow maintenance instructions and precautions can cause you to be seriously hurt or killed.

Always follow the procedures and precautions in this owner's manual.

Safety Precautions

- Make sure the engine is off before you begin any maintenance or repairs. This will eliminate several potential hazards:
 - **Carbon monoxide poisoning from engine exhaust.**
Be sure there is adequate ventilation whenever you operate the engine.
 - **Burns from hot parts.**
Let the engine and exhaust system cool before touching.
 - **Injury from moving parts.**
Do not run the engine unless instructed to do so.
- Read the instructions before you begin and make sure you have the tools and skills required.
- To reduce the possibility of fire or explosion, be careful when working around petrol. Use only a non-flammable solvent, not petrol to clean parts. Keep cigarette, sparks and flames away from all fuel-related parts.

Remember that an authorised Honda servicing dealer knows your mower best and is fully equipped to maintain and repair it.

To ensure the best quality and reliability, use only new, Honda genuine parts for repair and replacement.

8. MAINTENANCE - continued

MAINTENANCE SCHEDULE

REGULAR SERVICE PERIOD (4) Perform at every indicated month or operating hour interval, whichever comes first.		Each use	First month or 20 hrs.	Every 3 months or 50 hrs.	Every 6 months or 100 hrs.	Every year or 200 hrs.	Refer to page
ITEM							
Engine oil	Check level	○					19
	Change		○		○(3)		45
Air cleaner	Check	○					21
	Clean			○(1)			47
	Replace					○	47
Spark plug	Check-adjust				○		48
	Replace					○	48
Idle speed	Check-adjust					○(2)	—
Valve clearance	Check-adjust					○(2)	—
Combustion chamber	Clean	Every 250 hrs. (2)					—
Fuel tank and filter	Check	○					—
	Clean					○(2)	—
Fuel tube	Check	Every 2 years (Replace if necessary)(2)					—
Blade bolt tightness	Check	○					16
Grass bag	Check-clean	○					21
Throttle cable	Check-adjust					○(2)	—

- 1) Service more frequently when used in dusty areas.
- 2) These items should be serviced by your servicing dealer, unless you have the proper tools and are mechanically proficient. Refer to the Honda workshop manual for service procedures.
- 3) Change engine oil every 25 hours when used under heavy load or in high ambient temperatures.
- 4) For commercial use, log hours of operation to determine proper maintenance intervals.

8. MAINTENANCE - continued

ENGINE MAINTENANCE

Engine Oil Change

Drain the used oil while the engine is warm. Warm oil drains quickly and completely.

1. Turn the fuel valve to the OFF position to reduce the possibility of fuel leakage (see page 9).
2. Wipe the oil filler area clean, and then remove the oil filler cap/dipstick.
3. Place a suitable container next to the mower to catch the used oil, and then tilt the mower on its right side. The used oil will drain through the filler neck. Allow the oil to drain completely.

Please dispose the used motor oil and the containers in a manner that is compatible with the environment. We suggest you take it in a sealed container to your local recycling centre or service station for reclamation. Do not throw it in the trash, pour it on the ground or down a drain.

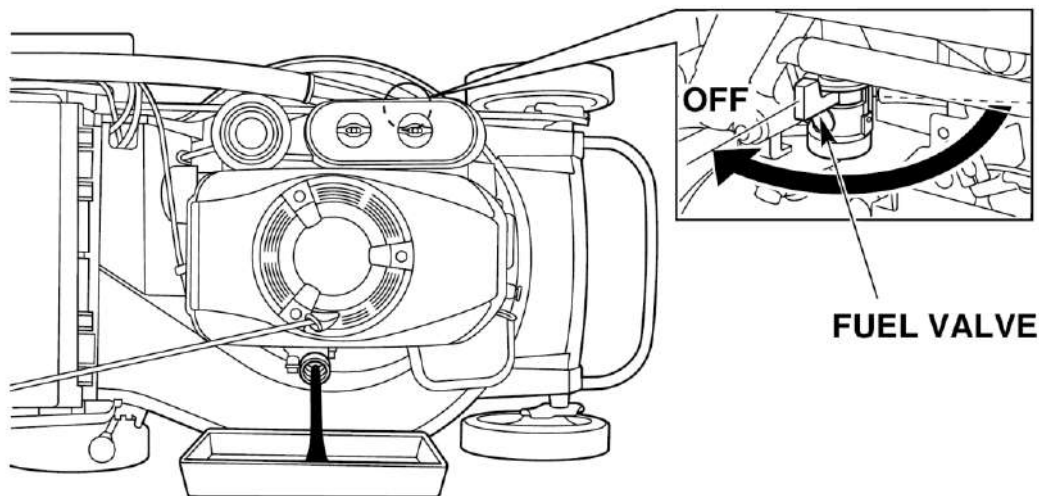

4. Fill with the recommended oil. Do not overfill; measure the oil level as shown on page 46.

Engine oil capacity: 0.65 Litre

NOTICE

Using non-detergent oil can shorten the engine's service life and using 2-stroke oil can damage the engine.

8. MAINTENANCE - continued

5. After changing the engine oil and before starting the engine, check the oil level with the mower on a level surface:
 - a) Wipe the dipstick clean.
 - b) Insert and remove the dipstick without screwing it into the filler neck. Check the oil level shown on the dipstick.
 - c) If the oil level is low, add oil to reach the upper limit mark on the dipstick. Do not overfill. If the engine is overfilled, the excess oil may get transferred to the air cleaner housing and air cleaner.

NOTICE

Running the engine with a low oil level can cause severe engine damage.

- d) Screw the oil filler cap/dipstick securely

OIL FILLER CAP/DIPSTICK

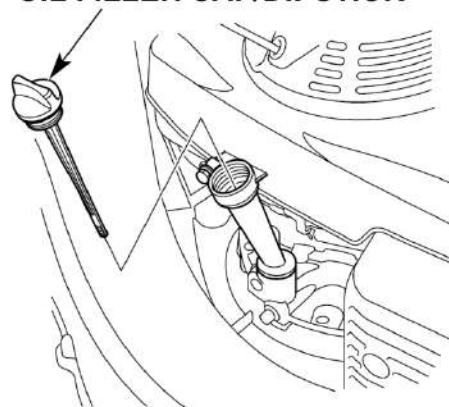

Engine Oil Recommendations

Oil is a major factor affecting performance and service life.

Use 4-stroke motor oil that meets or exceeds the requirements for API service classification SG or higher (or equivalent). Always check the API service label on the oil container to be sure it includes the letters SG or higher (or equivalent).

SAE 10W-30 is recommended for general use in Australia.

Please contact your local Honda Power Equipment Dealer for Genuine Oils.

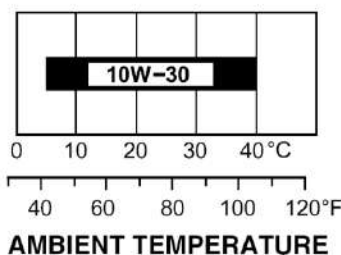
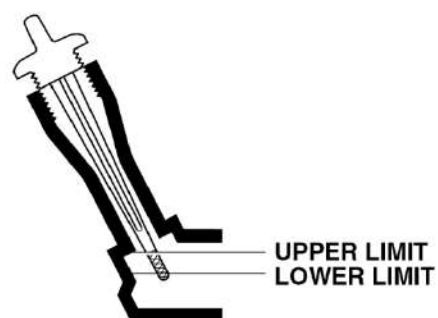

8. MAINTENANCE - continued

Air Cleaner Service

A dirty air cleaner will restrict air flow to the carburetor, reducing engine performance. If you operate the mower in very dusty areas, clean the air cleaner more often than specified in the MAINTENANCE SCHEDULE.

NOTICE

Operating the engine without an air filter or damaged filters, will allow dirt to enter the engine, causing rapid engine wear. This type of damage is not covered by Warranty.

1. Unscrew and remove the two air cleaner nuts, then remove the air cleaner cover.
2. Remove the filter elements from the air cleaner housing and remove the foam filter element from the paper filter element.
3. Inspect the filter elements for holes or tears; and replace them if damaged.

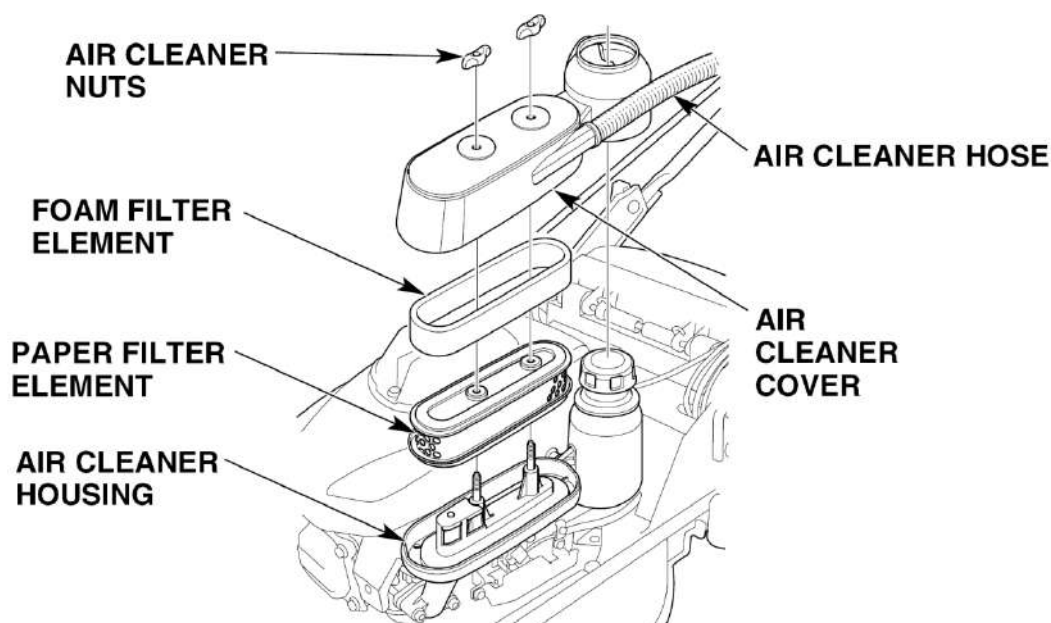

4. Clean the filter elements.
Paper filter element: Tap the filter several times on a hard surface to remove dirt, or blow compressed air (not exceeding 207kPa) through the filter from the inside. Never try to brush off dirt; brushing will force dirt into the fibres.

8. MAINTENANCE - continued

Foam element: Clean in warm soapy water, rinse and allow it to dry thoroughly. Or, clean in non-flammable solvent and allow it to dry. Dip the filter element in clean engine oil, and then squeeze out excess oil.

5. Wipe dirt from the inside of the air cleaner housing and cover, using a moist rag. Be careful to prevent dirt from entering the air duct that leads to the carburetor.
6. Reinstall the filters and cover and tighten the air cleaner nuts securely.

Spark Plug Service

Recommended spark plug: BPR5ES (NGK) or W16EPR-U (DENSO)

NOTICE

An incorrect spark plug can cause engine damage.

For good performance, the spark plug must be properly gapped and free of deposits.

1. Disconnect the spark plug cap and remove the dirt from the area.

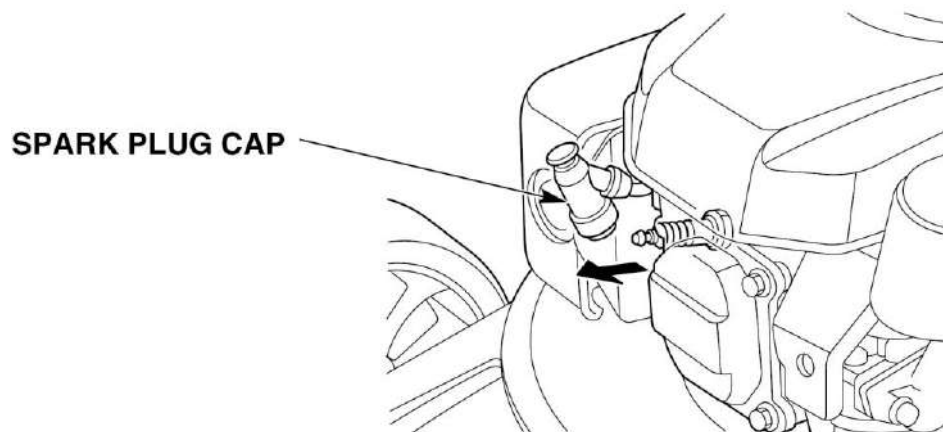

8. MAINTENANCE - continued

2. Use a spark plug wrench to remove the spark plug.
3. Inspect the plug; replace it if the electrode is worn, or if the insulator is cracked or chipped.
4. If you are going to reuse the spark plug, remove carbon deposits with a stiff wire brush.
5. Measure the spark plug gap with a suitable gauge. The gap should be 0.7-0.8mm. Correct the gap, if necessary by bending the side electrode.

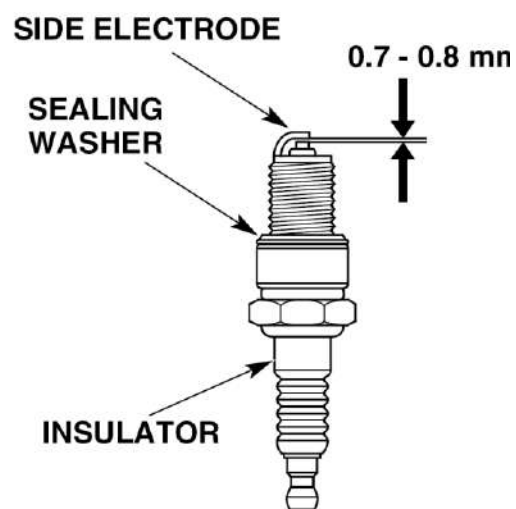
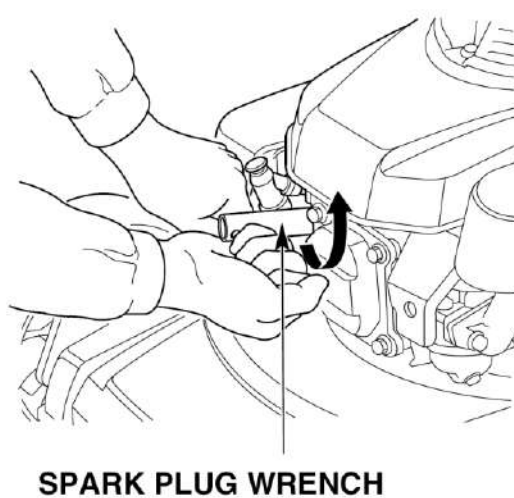

6. Install the spark plug carefully by hand, to avoid cross-threading.
7. After the spark plug seats, tighten with a spark plug wrench to compress the washer.

If reinstalling the old spark plug, tighten $\frac{1}{8}$ to $\frac{1}{4}$ turn after the spark plug seats.

If installing a new spark plug, tighten $\frac{1}{2}$ turn after the spark plug seats.

NOTICE

- A loose spark plug can overheat and damage the engine.
 - Over tightening the spark plug can damage the threads in the cylinder head.
8. Install the spark plug cap on the spark plug.

8. MAINTENANCE - continued

Carburetor Modification of Altitude Operation

At high altitude, the standard air-fuel mixture will be too rich. Performance will decrease and fuel consumption will increase. A very rich mixture will also foul the spark plug and cause hard starting.

High altitude performance can be improved by specific modifications to the carburetor. If you always operate your lawn mower at altitude above 1,500 metres, have your servicing dealer perform carburetor modifications.

Even with carburetor modification, engine horsepower will decrease about 3.5% for each 300 metres increase in altitude. The effect of altitude on horsepower will be greater than this if no carburetor modification is made.

NOTICE

When the carburetor has been modified for high altitude operation, the air-fuel mixture will be too lean for low altitude use. Operation at altitude below 1,500m with modified carburetor may cause the engine to overheat and result in serious engine damage. For use at low altitude, have your servicing dealer return the carburetor to original factory specifications.

Fuel Recommendations

Use unleaded petrol with a pump octane rating of 86 or higher. This engine is certified to operate on unleaded petrol. Unleaded petrol produces fewer engine and spark plug deposits and extends exhaust system life. Never use stale or contaminated petrol or an oil/petrol mixture. Avoid getting dirt or water in the fuel tank. Occasionally you may hear light “spark knock” or “pinging” (metallic rapping noise) while operating under heavy loads. This is no cause for concern. If spark knock or pinging occurs at a steady engine speed, under normal load, change brands of petrol. If spark knock or pinging persists, see an authorised Honda servicing dealer.

NOTICE

Running the engine with persistent spark knock or pinging can cause engine damage. Running the engine with persistent spark knock or pinging is misuse and the Warranty does not cover parts damaged by misuse. For oxygenated fuel information, refer to page 38.

8. MAINTENANCE - continued

BLADE REMOVAL AND INSTALLATION

If you have removed the blade assembly, always use a torque wrench to reinstall. Wear heavy gloves to protect your hands. To avoid weakening the blades or cause imbalance or poor cutting, the blades should be sharpened by trained staff at an authorised Honda servicing dealer. If you are replacing the blades, use Honda genuine replacement blades or equivalent.

Removal:

1. Turn the fuel valve to the OFF position.
2. Disconnect the spark plug cap, then tilt the mower to the right side, so the carburetor side is up.
3. Hold the blade disc firmly and remove the blade disc holder bolt. Set a flat blade screwdriver at the engine's bolt to prevent the blade disc from turning when removing the blade disc holder bolt.

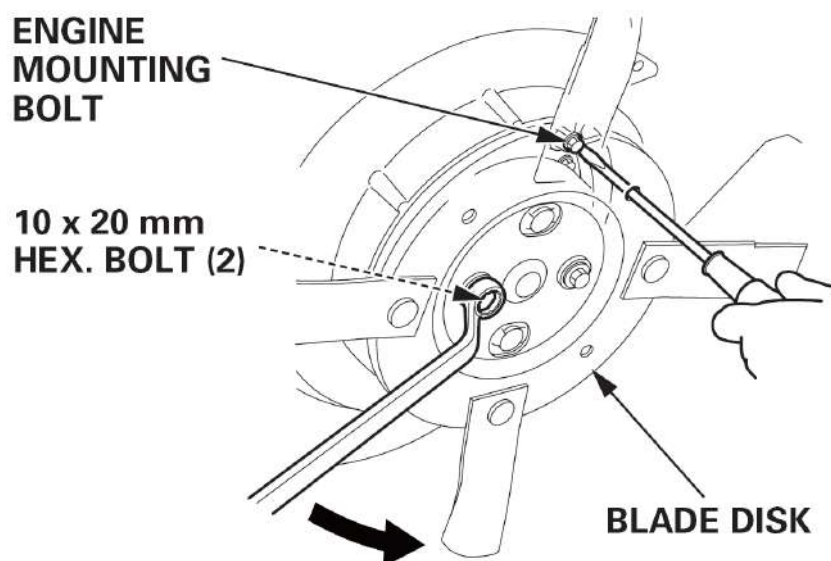
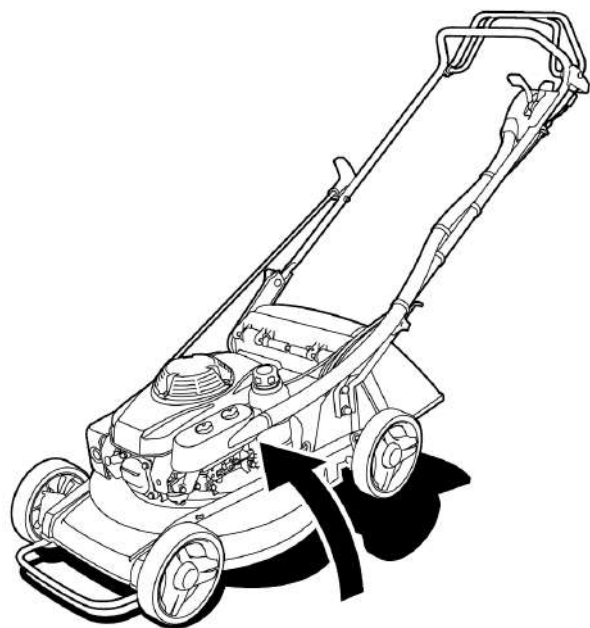

8. MAINTENANCE - continued

Illustration showing the blade disc holder bolts, washers, blades/blade disc removed.

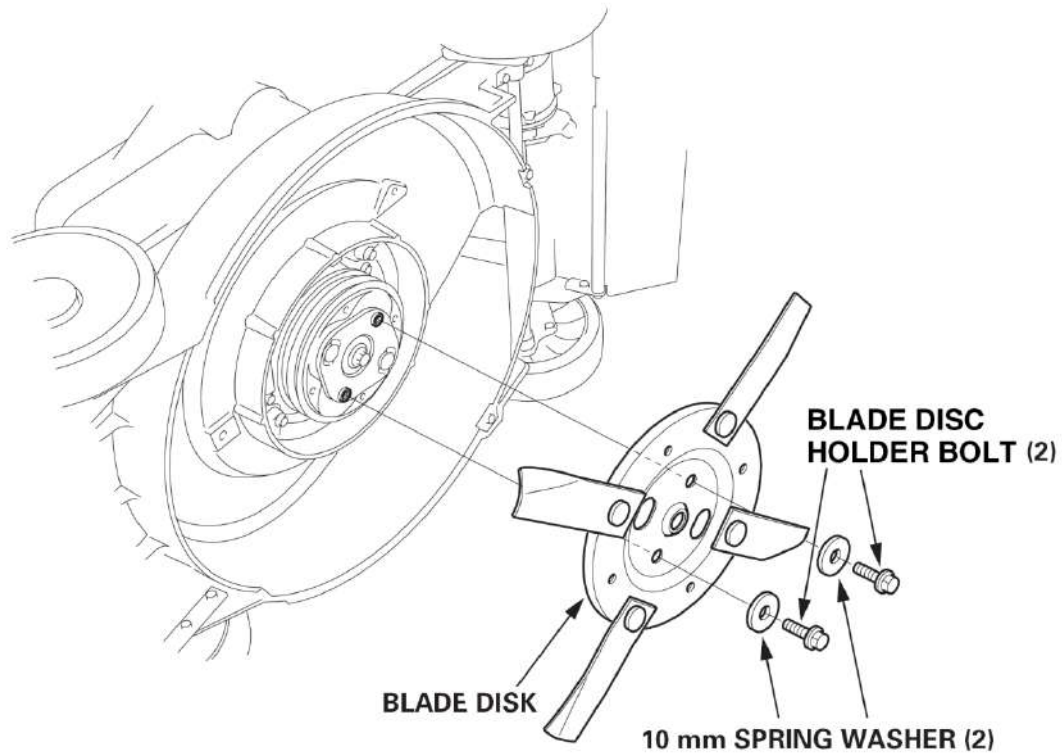

4. Remove the blade setting bolts, blades, spring washers, blade washers and self-lock nuts from the blade disc.

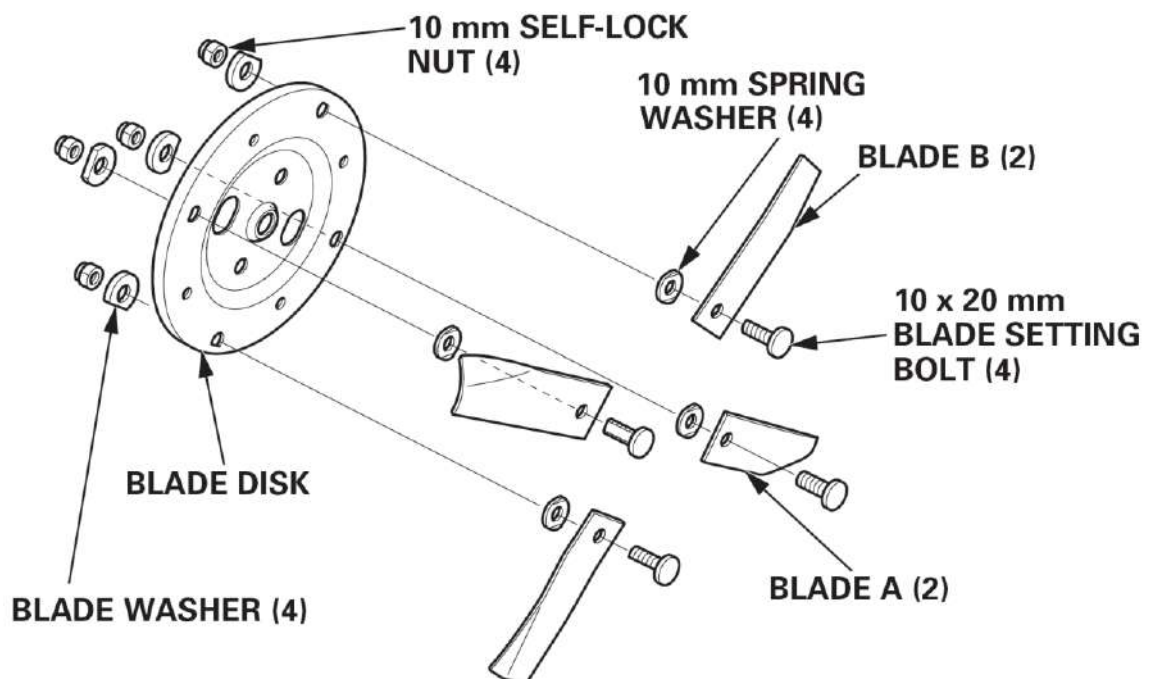

8. MAINTENANCE - continued

Installation:

1. Clean dirt and grass from the blades, blade disc and the inside on the cutter housing.
2. Install the blade, spring washers, blade washers and self-lock nuts to the blade disc using the blade setting bolt as described below.

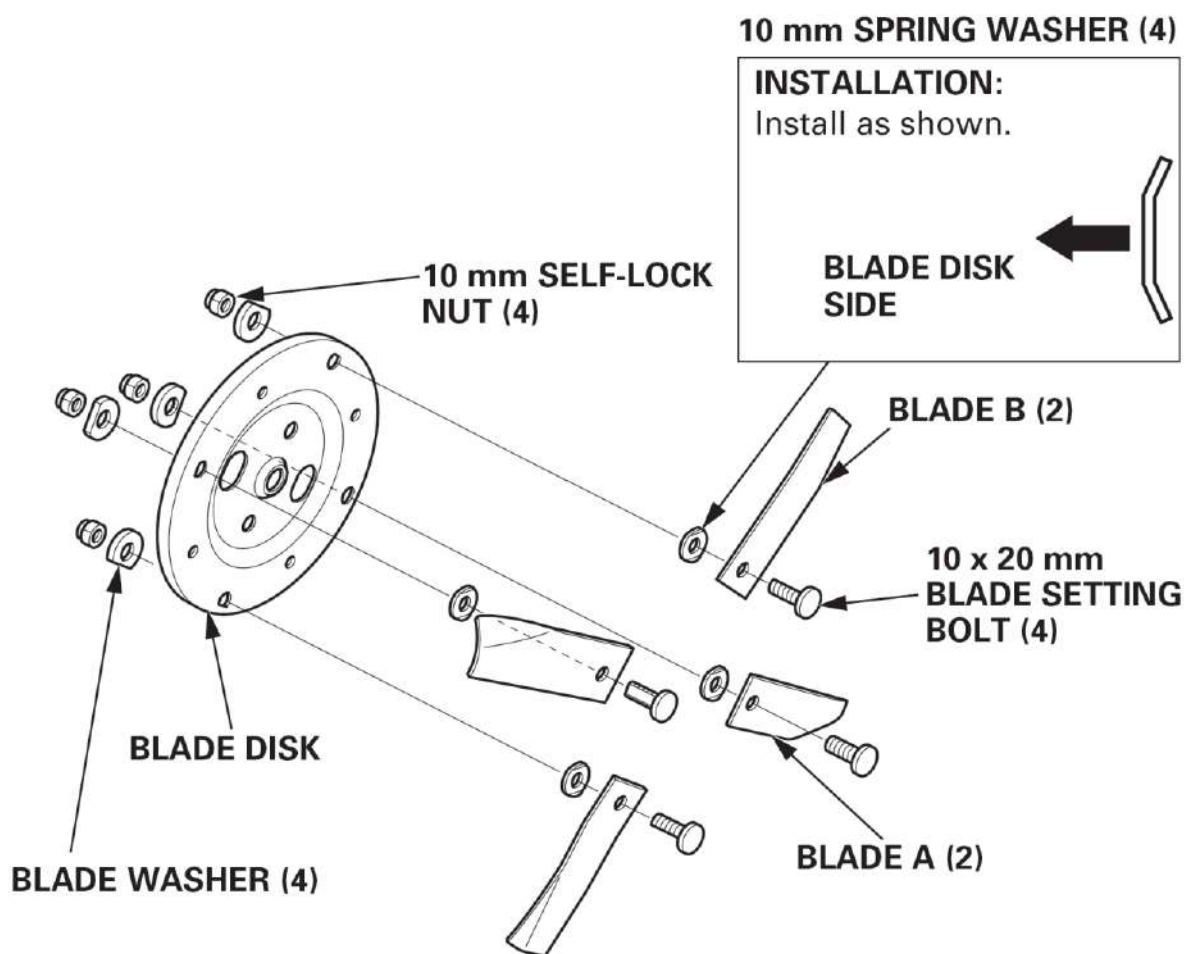

3. Tighten the self-lock nuts with a torque wrench. Prevent the blade disc from turning when tightening the self-lock nuts; tighten the self-lock nuts to the specified torque.

The blade setting bolts are specially designed for the mower. Should you ever have to replace them, use only Honda genuine parts. Otherwise, the blade may detach from the mower and cause serious injury.

Self-lock nuts tightening torque:

34.3 Nm (3.5 kgf.m)

8. MAINTENANCE - continued

4. Install the blade/disc, washers and blade disc holder bolts.

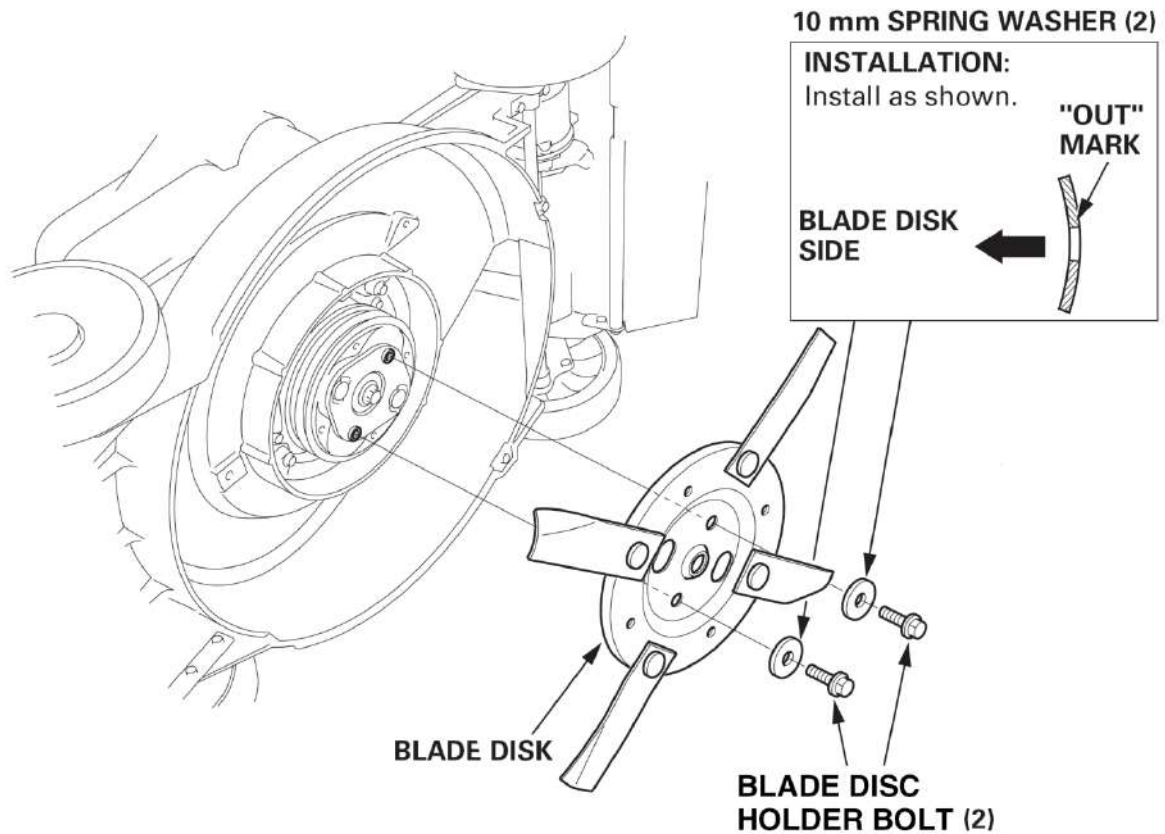

5. Hold the blade disc firmly and install the blade disc holder bolts.

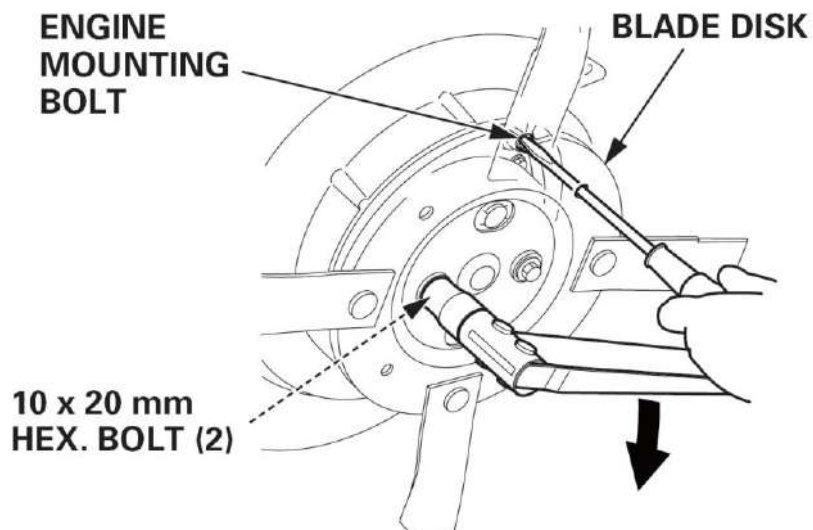

8. MAINTENANCE - continued

Tighten the blade disc holder with a torque wrench. Set a flat blade screwdriver at the engine's bolt to prevent the blade disc from turning when tightening the blade disc holder bolt, tighten the blade disc holder bolt to the specified torque.

Blade disc holder bolt tightening torque:

53.9 Nm (5.5 kgf.m)

6. After installing the blade/blade disc check that it does not interfere with the housing. If the blades contact the housing, consult an authorised Honda servicing dealer.

WARNING

A bent blade can be the cause of serious personal injury or accident.

If you don't have a torque wrench, have an authorised Honda servicing dealer tighten the blade setting bolts and the blade disc holder bolt before you use the mower. If the blade setting bolts and the blade disc holder bolt are over tightened, they could break. If the blade setting bolts and the blade disc holder bolt are not tightened enough, they could loosen or come out. In either case, it would be possible for the blade to fly off while you are operating the mower.

8. MAINTENANCE - continued

GRASS BAG CLEANING AND REPLACEMENT

Grass Bag Cleaning

Wash the bag with a garden hose and allow it to dry completely before use, a wet bag will clog quickly.

Grass Bag Replacement

Replace a worn or damaged bag with a Honda genuine bag or its equivalent.

Bag Removal

Unclip the plastic edges of the bag from the frame. Remove the bag from the frame.

Bag Installation

Insert the frame into the new bag. Clip the plastic edges to the frame as shown.

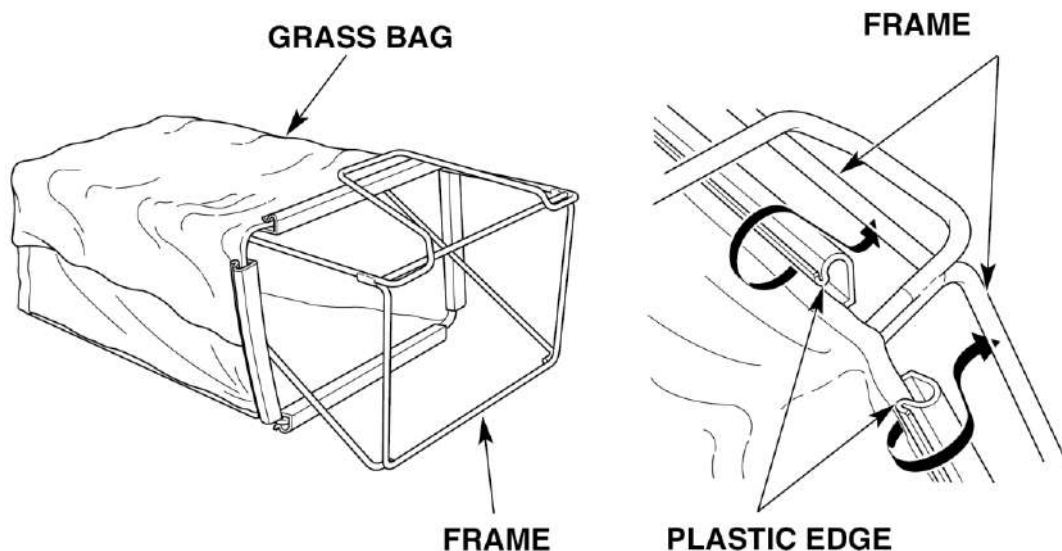

9. TROUBLESHOOTING

ENGINE PROBLEMS

Engine Will Not Start	Possible Cause	Correction
1. Check control positions.	Fuel valve OFF.	Turn fuel valve ON (page 24).
	Throttle lever in wrong position.	Move throttle lever to CHOKE position, unless the engine is warm (page 25).
2. Check fuel.	Out of fuel.	Refuel (page 20).
	Bad fuel; mower stored without treating or draining petrol or refuelled with bad petrol.	Drain fuel tank and carburetor (page 39). Refuel with fresh petrol (page 20).
3. Remove and inspect spark plug.	Spark plug faulty fouled or improperly gapped. Spark plug wet with fuel (flooded engine).	Clean, adjust or replace spark plug (page 48). Dry and reinstall spark plug. Start engine with throttle lever in HIGH position.
4. Take mower to an authorised Honda servicing dealer or refer to shop manual.	Fuel filter clogged, carburetor malfunction, ignition malfunction, valves stuck etc.	Replace or repair faulty components as necessary.

Loss of Power	Possible Cause	Correction
1. Check throttle position.	Throttle not set to HIGH.	Move throttle to HIGH (page 25).
2. Check grass height.	Grass too tall to cut.	Raise cutting height (page 23), cut narrower swath (page 33) or cut more frequently.
3. Check under cutter housing.	Cutter housing clogged.	Clean out cutter housing (page 37).
4. Check air filter.	Air filter clogged.	Clean or replace air filter (page 47).
5. Check fuel.	Bad fuel; mower stored without treating or draining petrol or refuelled bad petrol	Drain fuel tank and carburetor (page 39). Refuel with fresh petrol (page 20).
	Fuel filter clogged, carburetor malfunction, ignition malfunction, valves stuck etc.	Replace or repair faulty components as necessary.
6. Take mower to an authorised Honda servicing dealer or refer to shop manual		

9. TROUBLESHOOTING - continued

VIBRATION PROBLEMS

Excessive Vibration	Possible Cause	Correction
5. Check cutter housing and blades.	Grass and debris lodged under cutter housing	Clean out cutter housing (page 37).
	Blade loose, damaged or unbalanced by improper sharpening.	Tighten loose blade bolts. Replace damaged blade (page 51).
6. Take mower to an authorised Honda servicing dealer to repair.	Mechanical damage, such as a bent crankshaft.	Replace or repair faulty components as necessary.

MOWING AND BAGGING PROBLEMS

Poor Cut Quality or Poor Mowing/Bagging Performance	Possible Cause	Correction
7. Check that the throttle lever is in the HIGH position.	Engine speed is too slow or cut well.	Move throttle lever to the HIGH position (page 25)
8. Reduce forward speed.	Mower is moving too fast for lawn conditions.	Select a slower speed or release the drive clutch lever and push more.
9. Check cutting height adjustment levers.	Adjustment lever is set at incorrect positions.	Set lever at the correct height position (pages 23 and 33).
10. Check grass bag (if equipped).	Grass bag overfilled or clogged.	Empty the grass bag. Wash the grass bag if clogged with dirt (page 56).
11. Check the cutter housing and blades.	Cutter housing clogged.	Clean out the cutter housing (page 37).
	Blade dull, worn or damaged.	Sharpen or replace blade if necessary (page 51).
	Wrong blade installed.	Install correct blade (page 53).

10. SPECIFICATIONS

MOWER MODEL

Model	HRU216M1
Description Code	MATU
Type	TBUH

DIMENSIONS, WEIGHTS & CAPACITIES

Model	HRU216M1	
Overall Length	1,695mm	
Overall Width	570mm	
Overall Height*	1,050mm	
Dry Weight	53.0kg	
Wheel Base*	625mm	
Tread	Front	
	Rear	470mm
Cutting Width	530mm	500mm
Grass Bag Capacity	70ℓ	
Cutting Height	16-76mm (Adjustable, 11 stages)	
Fuel Tank Capacity	1.5ℓ	

*: Overall height and wheel base are measured with cutting height set at 28mm [third position from the bottom].

10. SPECIFICATIONS - continued

ENGINE DESIGN AND PERFORMANCE

Model	HRU216M1
Engine Model	GXV160H2
Engine Type	4-stroke, overhead valve, single cylinder
Displacement	163cm ³
Bore and Stroke	68 x 45mm
Compression Ratio	8.0 ± 0.2
Engine Net Power (in accordance with SAE J1349*)	2.7Kw (3.6HP) AT 3,000rpm
Engine Max. Net Torque (in accordance with SAE J1349*)	9.0 Nm (0.92 kgf.m) at 2,500rpm
Ignition System	Transistor type magneto ignition
Fuel	Unleaded petrol with a pump octane rating of 86 or higher
Engine Oil	SAE 10W-30, API SG or later
Engine Oil Capacity	0.65 ℓ
Spark Plug Type	BPR5ES (NGK), W16EPR-U (DENSO)
Spark Plug Gap	0.7 – 0.8mm
Maximum Engine Speed	3,000 + 0 rpm - 150 rpm
Idle Speed	1,700 ± 150 rpm
Valve Clearance (cold)	Intake: 0.15 ± 0.02mm Exhaust: 0.20 ± 0.02mm

The power rating of the engine indicated in this document is the net power output tested on a production engine model and measured in accordance with SAE J1349 at 3,000rpm (Engine Net Power) and at 2,500rpm (Engine Max Net Torque).

Mass production engines may vary from this value.

Actual power output for the engine installed in the final machine will vary depending on numerous factors, including the operating speed of the engine in application, environmental conditions, maintenance and other variables.

10. SPECIFICATIONS - continued

DRIVE TRAIN

Mechanism from engine to transmission		Shaft Drive					
Clutch	Type	Dog Clutch					
	Operation	Manual Lever					
Transmission	Type	Gear Transmission					
	Operation	Remote Control					
	Number of Speeds	3 Speeds					
	Lubrication System	Oil Bath & Splash					
	Lubricant	Hypoid Gear Oil SAE #90					
	Oil Capacity	0.2 ℓ					
	Ground Speed	<table border="1" style="display: inline-table; vertical-align: middle;"> <tr> <td>1st</td> <td>0.8 m/sec</td> </tr> <tr> <td>2nd</td> <td>1.1 m/sec</td> </tr> <tr> <td>3rd</td> <td>1.4 m/sec</td> </tr> </table>	1 st	0.8 m/sec	2 nd	1.1 m/sec	3 rd
1 st	0.8 m/sec						
2 nd	1.1 m/sec						
3 rd	1.4 m/sec						

11. SET-UP INSTRUCTION

UNPACKING

Remove all protective cardboards from the mower, including the piece around the handlebar.

Handlebar Setup

1. Remove the locking knobs from the handlebar to the handlebar mounting section of the cutter housing enough so you can raise the handlebar into the normal position.
2. Set the lower section of the handlebar to the handlebar mounting section of the cutter housing enough so you can raise the handlebar into the normal position.
3. Loosely install the washers and locking knobs.
4. Raise the handlebar in place.
5. Tighten the locking knobs securely.
6. Install the rope guide to the handlebar tighten the flange nut and lock nut securely.
7. Remove the wire bands from the cables.
8. Install the air cleaner hose to the air cleaner cover and throttle lever cover.

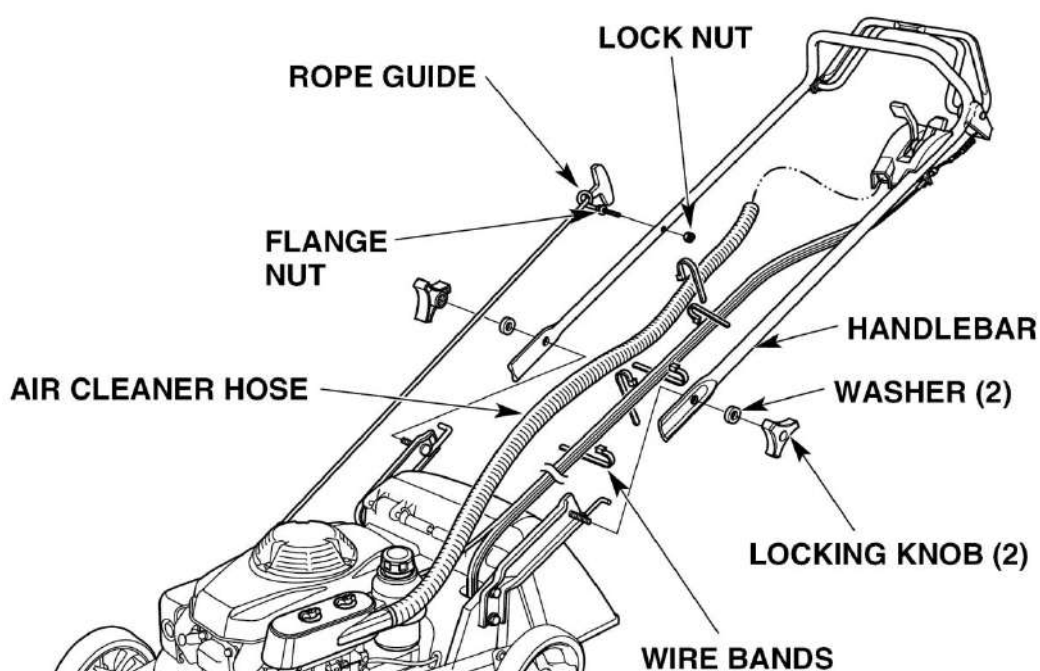

11. SET-UP INSTRUCTION -continued

9. Secure the wires and air cleaner hose with the wire band as shown below.
Secure the wires with the wire band as shown below.

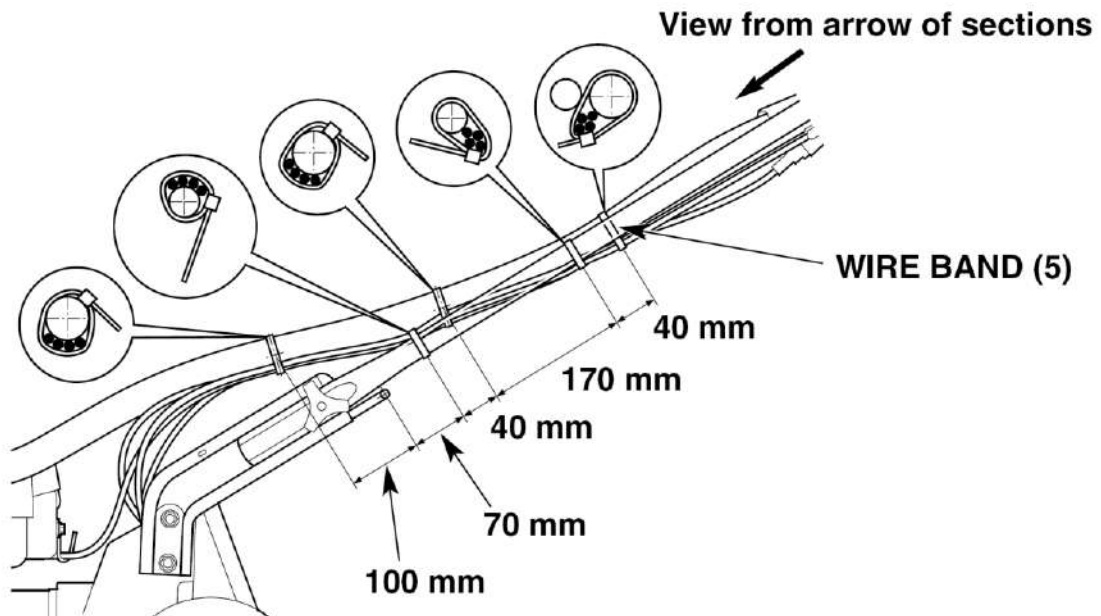

12. SERVICE SCHEDULE SHEET

Service Record First Year

1ST MONTH OR 20 HOUR SERVICE

Hours Use (Tanks x Hrs/Tank)	Date	Notes

Servicing Dealer Stamp	Date:
------------------------	-------

EVERY 6 MONTHS OR 100 HOUR SERVICE

Hours Use (Tanks x Hrs/Tank)	Date	Notes

Servicing Dealer Stamp	Date:
------------------------	-------

Service Record

Record further services here:

NEXT SERVICE

Hours Use (Tanks x Hrs/Tank)	Date	Notes

Servicing Dealer Stamp	Date:
------------------------	-------

NEXT SERVICE

Hours Use (Tanks x Hrs/Tank)	Date	Notes

Servicing Dealer Stamp	Date:
------------------------	-------

Here is an easy way to keep track of the hours your Honda lawnmower has done. Record how many hours you get from a tank of fuel, then simply record the number of tanks used. **TANKS X HOURS per TANK = TOTAL HOURS USE.**

HONDA

The Power of Dreams



Part Number: C9050